

**MVD and MVDLE Series Safety Shutoff Valves
Installation Instructions**

SPECIFICATIONS

MVD	Normally closed automatic shutoff valve, fast opening, fast closing. Adjustable max. flow.		
MVDLE	Normally closed automatic shutoff valve, slow opening, fast closing. Adjustable initial lift. Adjustable max. flow.		
Body size		Size	MVDLE Cycle Life and Cycle Time
MVD 505 & MVDLE 205		1/2" NPT	500,000 cycle life when cycled no faster than 20/hr
MVD 507 & MVDLE 207		3/4" NPT	Closing Time
MVD 510 & MVDLE 210		1" NPT	< 1 second
MVD 512 & MVDLE 212		1 1/4" NPT	Opening Time
MVD 515 & MVDLE 215		1 1/2" NPT	MVD series: < 1 sec.
MVD 520 & MVDLE 220		2" NPT	MVDLE series: 10 to 20 sec. at 70 °F
MVD 525 & MVDLE 225		2 1/2" NPT	Max. Flow Setting (MVD and MVDLE only)
MVD 530 & MVDLE 230		3" NPT	Adjustable from <10 to 100 % of total flow; <10 to 100 % of stroke
Gases	Natural gas, Propane, Butane; Other Noncorrosive gases. Suitable for up to 0.1% by volume, dry H ₂ S.		Initial Lift Adjustment (MVDLE series only)
Maximum Operating Pressure	MVD 7 PSI (500 mbar) UL,FM; 5 PSI (345 mbar) CSA MVDLE 3 PSI (200 mbar) UL,FM; 2 PSI (140 mbar) CSA		Adjustable from 0 to 70% of total flow; 0 to 25% of stroke
Maximum Closing Pressure	15 PSI (1000 mbar) FM		Materials in contact with Gas
Ambient / Fluid Temperature	-20 °F to +120 °F (-30 °C to +50 °C)		Housing: Aluminum and Steel Sealings on valve seats: NBR-based rubber
Electrical Ratings Available	120Vac/60Hz. 24Vac/60Hz in some models		Mounting Position
Enclosure Ratings Available	NEMA Type 12		Vertically upright to horizontal
Electrical Connection	Screw terminals with 1/2" NPT conduit connection		
Operating Time	100 % duty cycle		
Position Indication (optional)	Visual Indicator CPI 400 SPDT valve switch with visual indication		
MVD Cycle Life and Cycle Time	1,000,000 cycle life when cycled no faster than 100/hr		

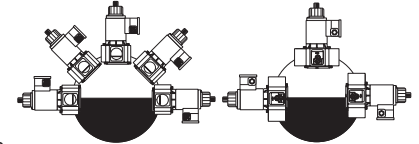

Test Port
Two 1/4" NPT upstream and two 1/4" NPT downstream ports

Approvals
UL Listed: File No.MH16727
CSA: Certificate: 1133914 & 1010989
FM Approved: Report J.1.0V9A8.AF
Commonwealth of Massachusetts Approved Product
Approval code G1-1107-35



CAPACITY

Capacity in CFH at pressure drop of 1 inch water column; natural gas, sp.gr.=0.64

Body size	Size	CFH
MVD 505 & MVDLE 205	1/2" NPT	250
MVD 507 & MVDLE 207	3/4" NPT	575
MVD 510 & MVDLE 210	1" NPT	825
MVD 512 & MVDLE 212	1 1/4" NPT	1250
MVD 515 & MVDLE 215	1 1/2" NPT	1700
MVD 520 & MVDLE 220	2" NPT	2700
MVD 525 & MVDLE 225	2 1/2" NPT	3900
MVD 530 & MVDLE 230	3" NPT	5100

Karl Dungs, Inc.

524 Apollo Drive, Suite 10 Lino Lakes, MN 55014 U.S.A.

Phone: (651) 792-8912 Fax: (651) 792-8919 E-mail: info@karldungusa.com

ATTENTION

- Read these instructions carefully.
- Failure to follow them and/or improper installation may cause explosion, property damage and injuries.
- The system must meet all applicable national and local code requirements such as but not limited to the following fuel gas codes: NFPA 54, IFGC (International Fuel Gas Code), or CSA B149.1 (for Canada) or the following equipment codes and standards: CSD-1, ANSI Z83.18, ANSI Z83.4/CSA 3.7, ANSI Z21.13/CSA 4.9, or CSA B149.3 (for Canada).
- Installation must be done with the supervision of a licensed burner technician.
- Check the ratings in the specifications to make sure that they are suitable for your application.
- Never perform work if gas pressure or power is applied, or in the presence of an open flame.
- Once installed, perform a complete checkout including leak testing.
- Verify proper operation after servicing.

MOUNTING

- Examine the valve for shipping damage.
- The main gas supply must be shut off before installation.
- The inside of the valve, threads and piping all must be clean and free of dirt. Failure to remove dirt/debris could result in valve damage or cause improper performance.



If the flow is not in the same direction of the arrows the valve will not operate properly.

Recommended Piping Procedure

- Use new, properly reamed and threaded pipe free of chips.
- Apply good quality pipe sealant, putting a moderate amount on the male threads only. If pipe sealant lodges on the valve seat, it will prevent proper operation. If using LP gas, use pipe sealant rated for use with LP gas.
- Do not thread pipe too far. Valve distortion and/or malfunction may result from excess pipe in the valve body.
- Apply counter pressure only a parallel jaw wrench only to the flats on the flange when screwing the pipe into the flanges.
- Do not overtighten the pipe. Follow the maximum torque values listed below.
- After installation is complete, perform a leak test.

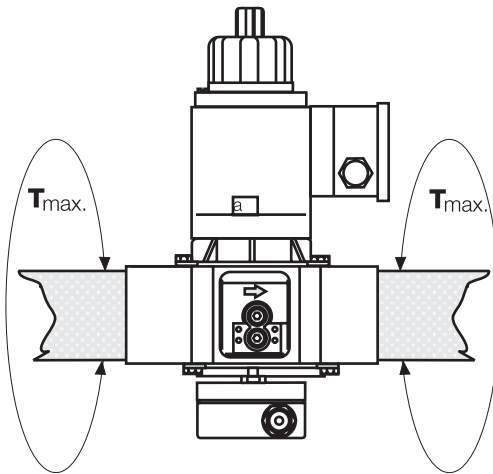

T = Torque

NPT	1/2"	3/4"	1"	1-1/4"	1-1/2"	2"	2 1/2"	3"
Tmax [lb-in]	443	752	1106	1770	1991	2213	2876	3540

WIRING

NOTE: Use 14 or 16 gauge wire rated for 95°C(200°F).

- Remove the wiring box cover to expose the three terminals.
- The wiring box can be rotated to accommodate the conduit connection.
- Knock out only one of the conduit connections on the side of the terminal box you wish to make your conduit connection to. Support the opposite side of the electrical box when knocking out the conduit connection.

- For NEMA Type 12 applications, attach 1/2" NPT conduit to the junction box.
- Use appropriate tools to connect the conduit to the electrical box.
- Make electrical connections to the valve using the wiring diagram.
- Replace wiring box cover.

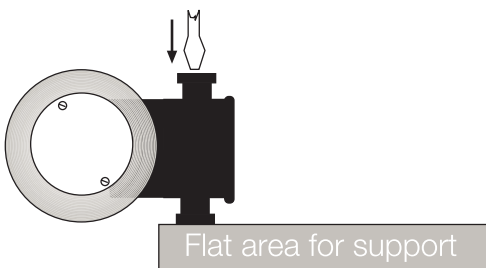

Flat area for support

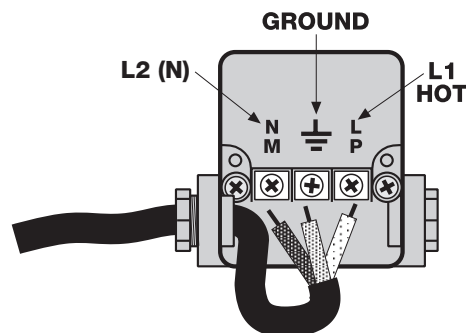

All wiring must comply with local electrical codes, ordinances and regulations.

PAINTING VALVE

- It is not recommended that this valve be painted. Painting covers date codes and other labels that identifies this valve.
- If the valve needs to be painted, a paint free of volatile organic components (VOC's) must be used. VOC's can damage valve orings, resulting in external gas leakage over time.
- During the painting process, use measures that will allow the valve's date code and other labeling information to be legible after the paint is dry.

PROTECTION FROM RADIANT HEAT

- Radiant heat must be considered as a heat source that could result in an ambient temperature higher than the rating of this valve.
- Provide proper shielding to protect against radiant heat.

VALVE ADJUSTMENT

Max. Flow Setting

- The valves are factory set with the flow adjustment fully open.

 Caution: Before igniting the burner, verify that gas flow at the factory setting does not create a light-off hazard.

- Locate the flow adjustment on top of the valve [MVD (black knob) MVDLE (base of the hydraulic brake)]. There are two screws, the holding screw is recessed and has a blue sealing compound on it, while the pan head screw protrudes from the cap.
- Loosen the pan head screw until you can freely rotate the flow adjustment.
- Turn clockwise for less gas or counterclockwise for more gas. (see arrows on valve)
- Check the flow at the burner with an orifice or flow meter.
- Tighten the pan head screw on the adjustment cap.

Initial Lift Adjustment (MVDLE series only)

This adjustment can vary the initial flow between 0 % and 70% of the total gas flow; 0 to 25% of stroke. All MVDLE valves are factory set with no initial lift.

To adjust the initial lift:

- Unscrew the small black cap on top of the flow adjustment cap to expose the initial lift adjustment knob.
- The black cap also serves as a tool; turn the cap over and insert it on the slot on the adjustment knob.
- Turn the knob clockwise for a min. initial lift or counterclockwise for a max. initial lift.
- Once the desired initial fast lift has been achieved, reinstall the black cap.

 Do not adjust or remove any screws or bolts which are sealed with a Red or Blue colored compound. Doing so will void all approvals and warranties.

Initial Lift Illustration:

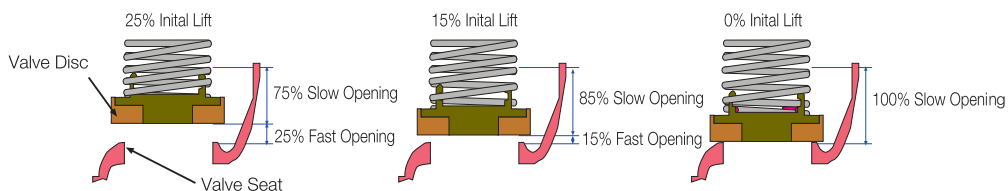

TEST PORTS

Test Port

The 1/4 inch NPT taps are available on both sides upstream of the valve seat and downstream of the valve seat.

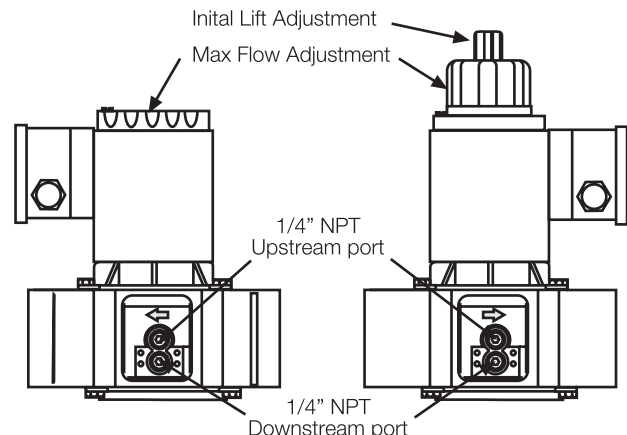

VALVE LEAKAGE TEST

This leak test procedure tests the external sealing and valve seat sealing capabilities of two MVD and MVDLE automatic safety shutoff valves in series. Only qualified personnel should perform this test.

It is required that this test be done on the initial system start-up, and then repeated at least annually. Possibly more often depending on the application, environmental parameters, and the requirements of the authority having jurisdiction.

SETUP

This test requires the following:

- A) Test nipples installed in the downstream pressure tap port of each automatic safety shutoff valve to make the required 1/4" hose connection in step 4.
- B) A transparent glass of water filled at least 1 inch from the bottom.
- C) A proper leak test tube. An aluminum or copper 1/4" rigid tube with a 45° cut at the end that is then connected to a 1/4" flexible hose of some convenient length provides for a more accurate leakage measurement. However, a 45° cut at the end of the 1/4" flexible hose will suffice, but it will not likely be as accurate as the rigid tube.
- D) For detecting external leakages, an all purpose liquid leak detector solution or a soapy water solution is required.

LEAK TEST PROCEDURE

Use the illustration below as a reference.

1. With the upstream ball valve open, the downstream ball valve closed and both valves energized, apply an all purpose liquid leak detector solution to the "External Leakage Test Areas" indicated in the illustration below, to any accessories mounted to the safety valve, and to all gas piping and gas components downstream the equipment isolation valve, and the inlet and outlet gas piping for each automatic safety shutoff valve. The presence of bubbles indicates a leak, which needs to be rectified before proceeding.
2. Then, de-energize the burner system and verify that both automatic safety shutoff valves are closed.
3. Close the upstream and downstream manual ball valve.
4. Open the downstream test nipple of the upstream valve, and connect the 1/4" flexible hose to the test nipple.
5. Slowly open the upstream manual ball valve, and then provide for some time to allow potential leakage to charge the test chamber before measuring the valve seat leakage.
6. Immerse the 1/4 in. tube vertically 1/2 in. (12.7 mm) below the water surface. If bubbles emerge from the 1/4" tube and after the leakage rate has stabilized, count the number of bubbles appearing during a 10 second period. (See chart below for allowable leakage rates.)
7. Close the test nipple and repeat the procedure for the downstream automatic safety shutoff valve except that valve #1 needs to be opened during the leakage test.

After completing the above tests proceed as follows:

8. Verify that the downstream manual ball valve is closed, and both automatic safety shutoff valves are de-energized.
9. Remove the flexible hose, and close all test nipples.
10. With the upstream manual ball valve open, energize both automatic safety shutoff valves.
11. Use soapy water to leak test all test nipples to ensure that there are no leaks.
12. If no leakage is detected, de-energize all automatic safety shutoff valves, and open the downstream manual ball valve.



WARNING: If leakage values are exceeded, replace valve immediately.

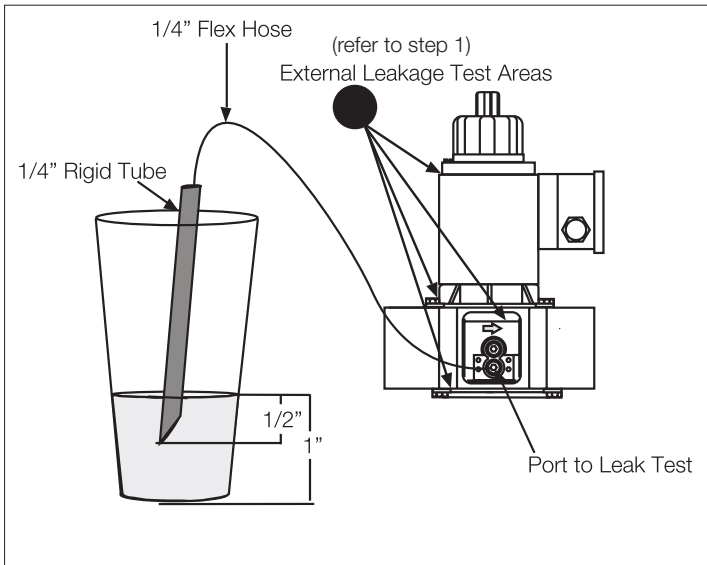

Valve Type	Allowable leakage (cc/hr) for up to 7 PSI inlet*	# of Bubbles in 10 Seconds (AIR)	# of Bubbles in 10 Seconds (Nat. Gas)	# of Bubbles in 10 Seconds (L.P.)
MVD 505 & MVDLE 205	235	4	5	4
MVD 507 & MVDLE 207	235	4	5	4
MVD 510 & MVDLE 210	277	5	6	5
MVD 512 & MVDLE 212	425	8	9	8
MVD 515 & MVDLE 215	425	8	9	8
MVD 520 & MVDLE 220	555	10	13	9
MVD 525 & MVDLE 225	620	11	14	10
MVD 530 & MVDLE 230	750	14	18	13

*Based on air, and test conditions per UL 429 Section 29. (Air or inert gas at a pressure of 1/4 psig and also at a pressure of one and one-half times maximum operating pressure differential, but not less than 1/2 psig. This test shall be applied with the valve installed in its intended position.) Volume of bubble defined in Table 2 of FCI 70-2-1998.

VALVE ACCESSORIES

Description	PN
CPI 400 Valve Switch	224-253A
Visual Indicator	217-665

REPLACEMENT PARTS

Valve Designation	Mag Type #	Coil P/N for 120 Vac	Coil P/N for 24 Vac	PCB for 120 Vac
MVD 505/6, & MVDLE 205/6	100 (ID# 216 963 for 120 Vac and 217 390 for 24Vac)	230-983	240-310	252-332A
MVD 507/6, MVD 510/6 & MVDLE 207/6, & MVDLE 210/6	200 (ID# 216 965 for 120 Vac and 217 391 for 24Vac)	230-986	240-311	252-333A
MVD 512/6, MVD 515/6, MVDLE 212/6, MVDLE 215/6, & MVDLE 220/6	300 (ID# 216 967)	230-989	Not available	252-334A
MVD 520/6 & MVDLE 225/6	400 (ID# 216 968)	230-991	Not available	252-334A
MVD 525/6 & MVDLE 230/6	500 (ID# 216 969)	230-992	Not available	252-334A
MVD 530/6	550 (ID# 216 970)	230-993	Not available	253-335A

Valve Designation P/N for Hydraulic Brake

MVDLE 205/6	223-159
MVDLE 207/6	223-158
MVDLE 210/6	223-158
MVDLE 212/6	223-158
MVDLE 215/6	223-158
MVDLE 220/6	223-158
MVDLE 225/6	223-157
MVDLE 230/6	223-157

Valve Designation P/N for Adjustment Knob

MVD 505/6	231-789
MVD 507/6	231-790
MVD 510/6	231-790
MVD 512/6	231-790
MVD 515/6	231-790
MVD 520/6	231-790
MVD 525/6	231-791
MVD 530/6	231-791

Valve Designation P/N for Cover for Junction Box

All MVD valves	252-336
----------------	---------

FLOW CURVE

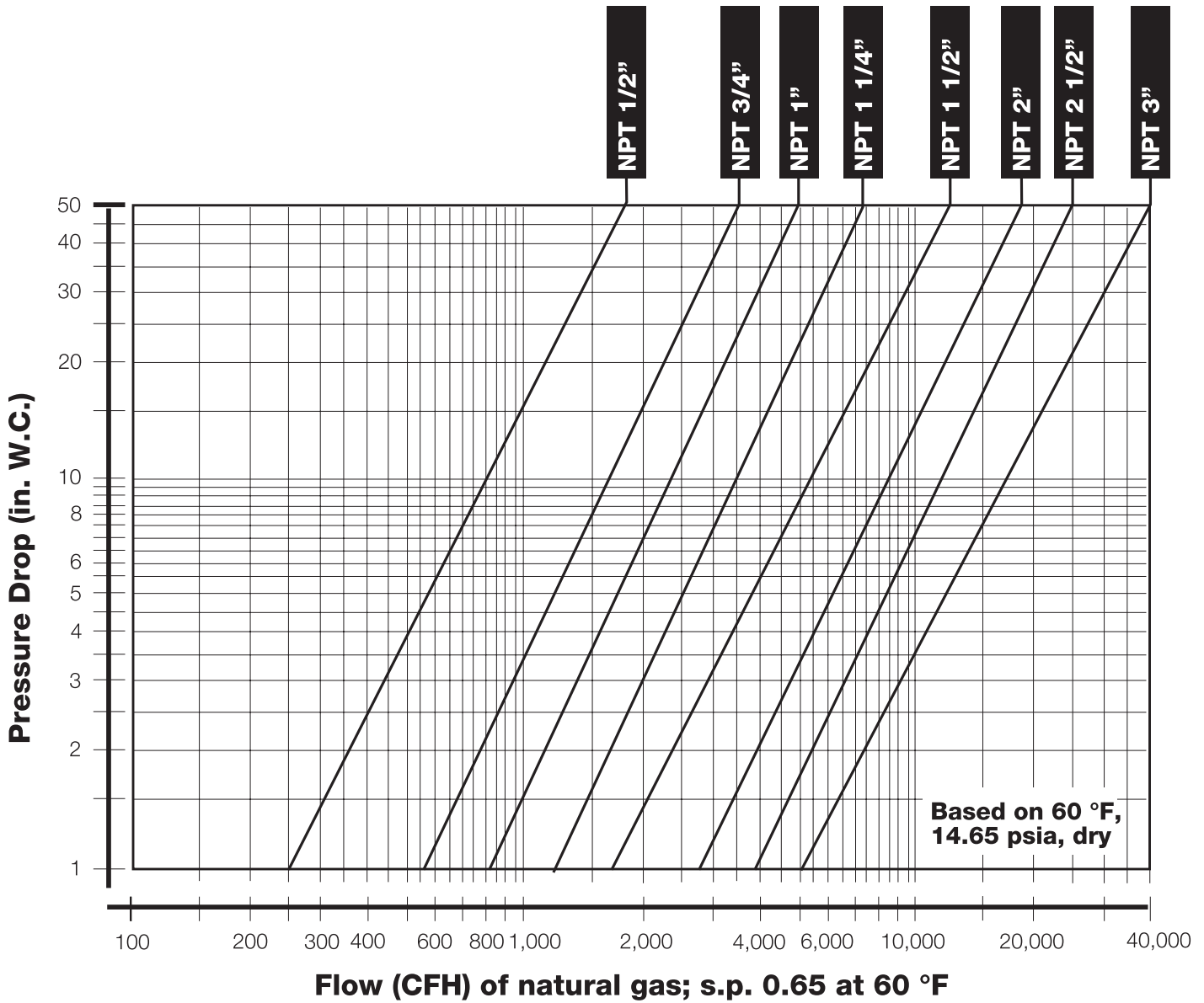

PRESSURE DROP FOR OTHER GASES

To determine the pressure drop when using a gas other than natural gas, use the flow formula below and f value located in the chart below to determine the “corrected” flow rate in CFH through the valve for the other gas used. For example, when using propane, divide the volume (CFH) of propane required for the application by the calculated value f (f = 0.66 for propane). Use this “corrected” flow rate and the flow curve above to determine pressure drop for propane.

$$\dot{V}_{\text{gas used}} = \dot{V}_{\text{Natural Gas}} \times f$$

f = correction factor to determine flow through valves with other gases.

$$f = \sqrt{\frac{\text{Spec. gravity of Natural Gas}}{\text{Spec. gravity of gas used}}}$$

Type of gas	Density [kg/m ³]	sg	f
Natural gas	0.81	0.65	1.00
Butane	2.39	1.95	0.58
Propane	1.86	1.50	0.66
Air	1.24	1.00	0.80