

# CPI 400 Valve Switch and Position Indicator Installation Manual

## SPECIFICATIONS

Closed position indicator CPI 400 visually and electrically indicates when the valve is either in the closed or open position. Mounts directly to the DMV, SV, and MVD series valves. When the valve is closed a orange light is visible, when the valve is open a green light is visible.

### Gases

Natural gas, propane, butane, noncorrosive gases, and air. Suitable for up to 0.1% by volume, dry H<sub>2</sub>S when used with nickel plated brass adapter.

### Switch Type

SPDT

### Switch Action

Valve open: Green light  
Valve closed: Orange light

### Contact Rating

10 A res, 8 FLA, 48 LRA @120 Vac  
When used, the 24Vdc/Vac indicator light consumes 20mA when energized.

### Enclosure

NEMA Type 4

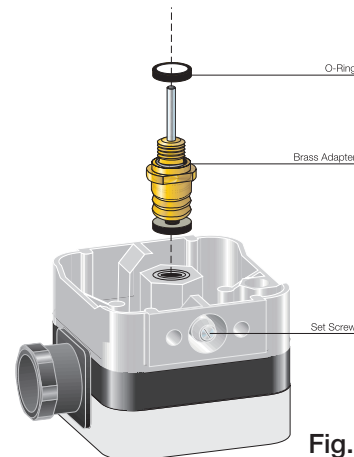

Fig. 1

## ATTENTION

- Read these instructions carefully.
- Failure to follow them and/or improper installation may cause explosion, property damage and injuries.
- Installation must be done with the supervision of a licensed burner technician.
- Check the ratings in the specifications to make sure that they are suitable for your application.
- Never perform work if gas pressure or power is applied, or in the presence of an open flame.
- Once installed, perform a complete checkout including leak testing.
- Verify proper operation after servicing.
- The system must be installed, used, and maintained to meet all applicable national and local code requirements such as but not limited to NFPA 86, CSD-1, ANSI Z21.13, UL 795, NFPA 85, or CSA B149.3.

## MOUNTING

### Mounting

- The valve must be de-energized and the gas supply shut off before mounting the CPI.
- Disconnect all power to the switch before beginning to prevent electrical shock and equipment damage.

### Mounting Procedure (reference Fig. 1 above)

- **IMPORTANT!! Before mounting the brass adapter to the valve or to the CPI 400, use your fingers to verify that the pin slides freely inside the brass adapter. If this pin does not slide freely, apply a large enough force to the appropriate side to free the pin.**
- Using a 5mm hex wrench, remove the plug and its o-ring located at the bottom of the valve.
- Verify that the brass adapter has a clean o-ring and its threads and the groove into which the brass adapter mounts, are clean and in good condition.

- Mount the brass adapter into the valve.
- Use a 9/16" (14 mm) open end wrench and torque to 44 in-lbs (5Nm), which is about 1/4 turn (after finger tight). DO NOT overtighten.
- Mount the CPI switch onto the brass adapter. Push the CPI housing towards the valve until it stops.
- Turn/Position the CPI so that the wiring and conduit connection apply the least amount of torque as possible.
- Tighten the set screw so that the CPI housing is secured to the brass adapter.
- Do not turn the CPI 400 after tightening the set screw; this may strip the brass adapter. The brass adapter could loosen and the assembly may leak.
- Perform a leak test to verify that no leakage occurs around the o-ring.

Karl Dungs, Inc

524 Apollo Drive, Suite 10 Lino Lakes, MN 55014 U.S.A.

Phone: (651) 792-8912 Fax: (651) 792-8919 E-mail: info@karldungsusa.com

## Wiring

### Required Wiring:

- Do not exceed the switches electrical ratings.
- Use 14 or 16 gauge wire for at least 75°C (167°F).
- For NEMA 4 applications, NEMA 4 conduit or wiring methods must be used.
- Run one wire (the COMMON) to the L1 terminal, one to the GROUND terminal, one from the terminal 2 “Proof Terminal” to the Proof of Closure terminal of the Flame Safeguard, and one (the NEUTRAL) to L2 on the CPI 400.

**NOTE:** If equipment neutral is not wired to L2 on the CPI 400, the lights will not properly indicate the valve position. The ORANGE light should be on when the valve is closed, The GREEN light should be on when the valve is open (FM and NPFA 86 requirement).

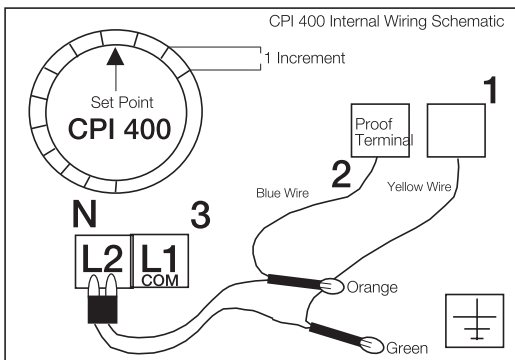

Fig. 2

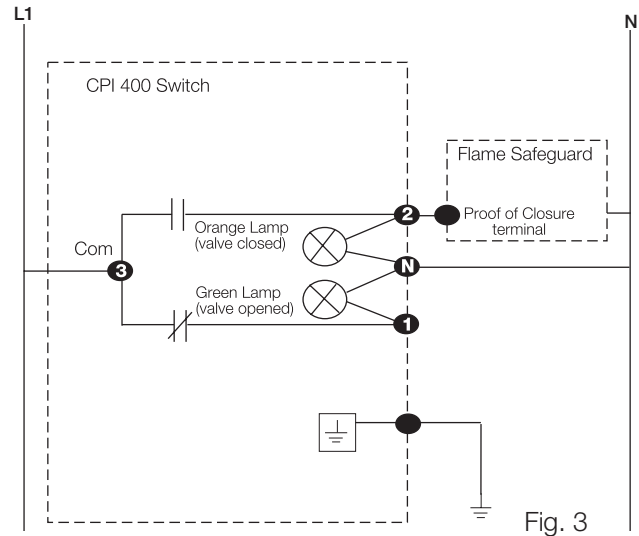

Fig. 3

**⚠ Do not wire this switch to close a circuit that will directly power another safety shutoff valve. Doing so could result in a safety valve being energized and opened rather than remaining closed.**

## Calibration and Testing

The CPI 400 must be calibrated to the specific valve it is used on. Failing to properly calibrate this switch may lead to nuisance problems or to an unsafe startup condition.

### Calibrating the CPI: (Reference Fig. 2)

- The CPI must be properly mounted to the valve, and the valve must be closed.
- Disconnect all power to the CPI 400 before adjusting to prevent electrical shock and equipment damage.
- Remove clear cover.
- Turn the adjustment dial counterclockwise until it stops.
- Then turn the adjustment dial clockwise until the switch makes. If there is too much noise to hear the switch trip, proceed to **Calibrating the CPI in noisy environments**.
- Note the position of the set point in reference to the white lines on the scale.
- Turn the adjustment dial **two additional** increments clockwise to the same relative position.
- Replace clear cover, the CPI is now adjusted.

### Calibrating the CPI in noisy environments:

- Verify that there are no stray wires that are potentially a shock hazard while the dial is being manually adjusted.

- Apply 120Vac to terminals L1 and L2 of the CPI.
- Turn the adjustment dial counterclockwise until it stops. The GREEN light should be illuminated.
- Then turn the adjustment dial clockwise until the RED light illuminates.
- Note the position of the set point in reference to the white lines on the scale.
- Turn the adjustment dial **two additional** increments clockwise to the same relative position.
- Replace clear cover, and the CPI is now ready for service.

### Annual Testing

- Perform a switch continuity test at least annually to verify that there is continuity between the switch contacts T3 (COM) and T2 (Proof Terminal), and verify that there is no continuity between the switch contacts T3 (COM) and T1.
- Then, energize the valve that the CPI is mounted to, and verify that there is continuity between the switch contacts T3 (COM) and T1. Then verify that there is no continuity between the switch contacts T3 (COM) and T2.
- If any above check fails, do not use the CPI and contact DUNGS immediately.

## Replacement Parts

Clear plastic cover	240-837
120Vac neon lights (one orange and one green)	229-338
24Vdc neon lights (one red and one green)	248-183
1/2"NPT conduit adapter (PG 11)	220-566

Brass adapter (standard)	224-417
Brass adapter (Ni plated)	224-417B