

**DMV-D(LE) 7../602 Dual Safety Shutoff Valve
Installation Instructions**

SPECIFICATIONS

DMV-D/602 Two normally closed safety shut off valves in one housing. Fast opening, fast closing. Adjustable max. flow on valve 2.

DMV-DLE/602 Two normally closed safety shut off valves in one housing. Valve 1 fast opening, fast closing. Valve 2 slow opening, fast closing. Adjustable max. flow and initial lift on valve 2.

| Body size | Flange Size |
|-------------------|--------------------|
| DMV-D(LE) 701/602 | 1/2" - 1" NPT |
| DMV-D(LE) 702/602 | 1" - 2" NPT |
| DMV-D(LE) 703/602 | 1" - 2" NPT |

Gases
Natural gas, propane, butane, other noncorrosive gases.

Maximum Operating Pressure
7 PSI (500 mbar)

Ambient / Fluid Temperature
-40 °F to +150 °F (-40 °C to +65 °C)

Electrical Ratings
110 to 120 Vac / 50 to 60 Hz
220 to 240 Vac / 50 to 60 Hz
24 Vac / 50 to 60 Hz
24 Vdc

Power Consumption: (Both valves inclusive)
DMV-D(LE) 701: 45 VA
DMV-D(LE) 702: 65 VA
DMV-D(LE) 703: 90 VA

Electrical Connection
DIN-Connector with 1/2" NPT conduit adapter

Operating Time
100 % duty cycle

Classification of Valve V1 and V2
Safety Shut Off Valve: UL 429, FM 7400
ANSI Z21.21 • CSA 6.5 C/I Valves

Closing Time (Valve 1 & Valve 2)
< 1 second

Opening Time

DMV-D/602: V1 & V2 < 1 sec.
DMV-DLE/602: V1 < 1 sec.; V2 10 to 20 sec. at 70 °F

Main Flow Setting (DMV-D/602 & DMV-DLE/602)

Adjustable on V2: <10 to 100% of total flow

Initial Lift Adjustment (DMV-DLE/602)

Adjustable on V2: 0 to 70 % of total flow

Materials in contact with Gas

Housing: Aluminum, Steel, free of nonferrous metals.
Sealings on valve seats: NBR-based rubber.

Mounting Position

Solenoid upright vertical to solenoid horizontal

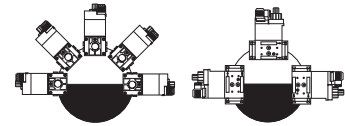

Strainer

23 Mesh, installed in the housing upstream V1

Test Port

G 1/8 ISO 228 taps available on both sides; upstream of V1, between V1 and V2, downstream of V2, and on both flanges

Position Indication (optional)

Visual Indicator and CPI 400 with visual indication and electrical valve switch (SPDT)

Approvals

UL Recognized Component: File No. MH16727
CSA Certified: File No.157406
FM Approved: ReportJ.1.1Z6A0.AF
Commonwealth of Massachusetts Approved Product
Approval code G1-1107-35



ATTENTION

- Read these instructions carefully.
- Failure to follow them and/or improper installation may cause explosion, property damage and injuries.
- Installation must be done with the supervision of a licensed burner technician.
- Check the ratings in the specifications to make sure that they are suitable for your application.
- Never perform work if gas pressure or power is applied, or in the presence of an open flame.
- Once installed, perform a complete checkout including leak testing.
- Verify proper operation after servicing.
- The system must meet all applicable national and local code requirements such as but not limited to the following fuel gas codes: NFPA 54, IFGC (International Fuel Gas Code), or CSA B149.1 (for Canada) or the following equipment codes and standards: CSD-1, NFPA 86, NFPA 37, ANSI Z83.4/CSA 3.7, ANSI Z83.18, ANSI Z21.13/ CSA 4.9, or CSA B149.3 (for Canada).

MOUNTING

Setup

- Examine the DMV-D(LE)/602 for shipping damage.
- The main gas supply must be shut off before starting the installation.
- The inside of the DMV-D(LE)/602, the flanges, and piping must be clean and free of dirt, remove all dirt and debris before installing the DMV-D(LE)/602. Failure to remove dirt/debris could result in valve damage or improper performance.

Recommended Procedure to Mount the Flanges

- Unpack the DMV-D(LE) valve and remove the 8 M6 (M8) socket cap head screws using a 5 mm (6 mm) Allen wrench.
- Remove the two white protective plastic covers from the DMV-D(LE) body.
- Make sure the o-rings and the grooves are clean and in good condition.
- Install the DMV-D(LE) with the gas flow matching the direction indicated by the arrows on the casting.
- Mount the DMV-D(LE) only with the solenoid vertical upright to horizontal.
- Clean the mounting surface of the flanges. Make sure they are in good condition.

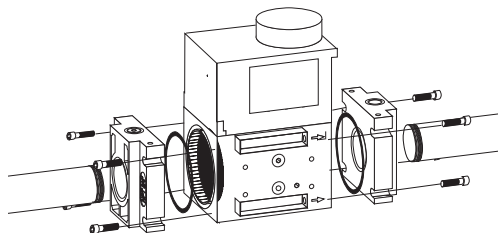

CAUTION: If the flow is not in the same direction of the arrows the valves will not operate properly.

- Attach the DMV-D(LE) to the flanges using the M6 (M8) socket cap screws supplied.
- Use a 5mm Allen wrench for the DMV-D(LE) 701
- Use a 6mm Allen wrench for the DMV-D(LE) 702/703.
- Tighten the screws in a crisscross pattern.
- Do not overtighten the screws. Follow the maximum torque values below.

Recommended Torque

| M6 | M8 | Screw Size |
|----|-----|------------|
| 62 | 134 | [lb-in] |

Recommended Piping Procedure

- Use new, properly reamed and threaded pipe free of chips.
- Apply good quality pipe sealant, putting a moderate amount on the male threads only. If pipe sealant lodges on the valve seat, it will prevent proper operation. If using LP gas, use pipe sealant rated for use with LP gas.
- Do not thread pipe too far. Valve distortion and/or malfunction may result from excess pipe in the valve body.
- Apply counter pressure only a parallel jaw wrench only to the flats on the flange when screwing the pipe into the flanges.
- Do not overtighten the pipe. Follow the maximum torque values listed below.

Recommended Torque for Piping

| 1/2" | 3/4" | 1" | 1-1/4" | 1-1/2" | 2" | NPT pipe |
|------|------|-----|--------|--------|------|----------|
| 375 | 560 | 750 | 875 | 940 | 1190 | [lb-in] |

- After installation is complete, perform a leak test.

WIRING (VAC or VDC)

- Disconnect all power to the valves before wiring to prevent electrical shock and equipment damage.
- Do not exceed the electrical ratings given in the specifications and on the valve.
- Attach a flexible 1/2" NPT conduit to the DIN connector.
- Route the wires through the conduit and the DIN connector.
- Use 14 or 16 guage wire for at least 75°C (167°F).
- Connect the wiring to the appropriate screw terminals in the DIN connector. See diagram to the right.
- The + and - designation indicate the correct terminal connections for VDC.
- Plug the DIN connector to the terminals. Fasten the DIN connector with the screw supplied. Torque to 5 lb-in.

DIN Connector screw terminal connections

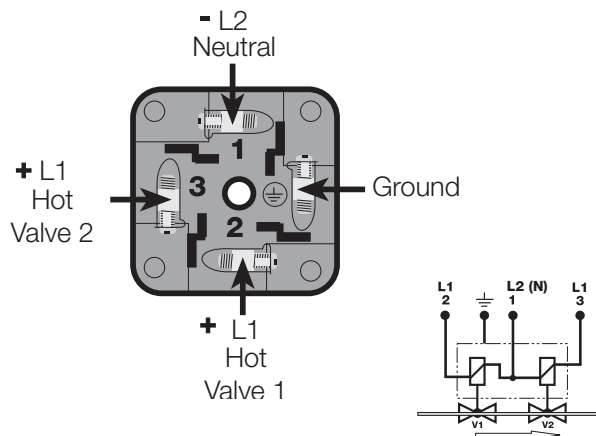

CAUTION: All wiring must comply with local electrical codes, ordinances and regulations. An ultimate electrical enclosure must be provided.

PAINTING VALVE

- It is not recommended that this valve be painted. Painting covers date codes and other labels that identifies this valve.
- If the valve needs to be painted, a paint free of volatile organic compounds (VOC's) must be used. VOC's can damage valve orings, resulting in external gas leakage over time.
- During the painting process, use measures that will allow the valve's date code and other labeling information to be legible after the paint is dry.

PROTECTION FROM RADIANT HEAT

- Radiant heat must be considered as a heat source that could result in an ambient temperature higher than the rating of this valve.
- Provide proper shielding to protect against radiant heat.

VALVE ADJUSTMENT

Flow Setting

- The valves are factory set with the flow adjustment fully open.
- Locate the flow adjustment knob on top of valve 2 on the DMV-D/602 (black knob). For DMV-DLE/602 it's the hydraulic brake. There are two screws, the holding screw is recessed and has a blue sealing compound on it, while the pan head screw protrudes from the cap.
- Loosen the pan head screw until you can freely rotate the flow adjustment.
- Turn clockwise for less gas or counterclockwise for more gas.
- Check the flow at the burner with an orifice or flow meter.
- Tighten the pan head screw on the adjustment cap.

Initial Lift Adjustment (DMV-DLE/602 only)

The initial lift adjustment varies the initial gas flow through the valve as the valve seat begins to open. This adjustment can vary the initial flow between 0 % and 70% of the total gas flow; 0 to 25% of stroke. All DMV-DLE/602 valves are factory set with no initial lift. To adjust the lift proceed as follows:

- Unscrew the small black cap on top of the flow adjustment cap to expose the initial lift adjustment knob.
- The black cap also serves as tool; turn the cap over and insert it on the slot on the adjustment knob.
- Turn the knob clockwise for a min. initial lift or counterclockwise for a max. initial lift.
- Once the desired initial fast lift has been achieved, reinstall the black cap.



Do not adjust or remove any screws or bolts which are sealed with a Red or Blue colored compound. Doing so will void all approvals and warranties.

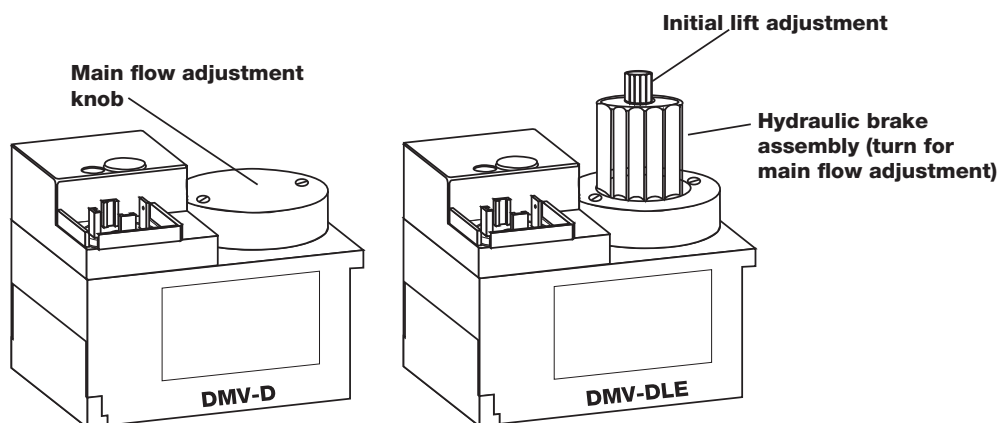

VALVE LEAKAGE TEST

This leak test procedure tests the external sealing and valve seat sealing capabilities of the DMV automatic safety shutoff valve. Only qualified personnel should perform this test.

It is required that this test be done on the initial system start-up, and then repeated at least annually. Possibly more often depending on the application, environmental parameters, and the requirements of the authority having jurisdiction.

SETUP

This test requires the following:

- A) Test nipples installed in the downstream pressure tap port of each automatic safety shutoff valve to make the required 1/4" hose connection in step 4.
- B) A transparent glass of water filled at least 1 inch from the bottom.
- C) A proper leak test tube. An aluminum or copper 1/4" rigid tube with a 45° cut at the end that is then connected to a 1/4" flexible hose of some convenient length provides for a more accurate leakage measurement. However, a 45° cut at the end of the 1/4" flexible hose will suffice, but it will not likely be as accurate as the rigid tube.
- D) For detecting external leakages, an all purpose liquid leak detector solution or a soapy water solution is required.

LEAK TEST PROCEDURE

Use the illustration below as a reference.

1. With the upstream ball valve open, the downstream ball valve closed and both valves energized, apply an all purpose liquid leak detector solution to the "External Leakage Test Areas" indicated in the illustration below, to any accessories mounted to the safety valve, and to all gas piping and gas components downstream the equipment isolation valve, and the inlet and outlet gas piping of the automatic safety shutoff valve. The presence of bubbles

indicates a leak, which needs to be rectified before proceeding.

2. Then, de-energize the burner system and verify that both automatic safety shutoff valves are closed.
3. Close the upstream and downstream manual ball valve.
4. Using a screwdriver, slowly open the V1 test nipple (port 3) by turning it counter clockwise to depressurize the volume between the two valves, and connect the 1/4" flexible hose to the test nipple.
5. Slowly open the upstream manual ball valve, and then provide for some time to allow potential leakage to charge the test chamber before measuring the valve seat leakage.
6. Immerse the 1/4 in. tube vertically 1/2 in. (12.7 mm) below the water surface. If bubbles emerge from the 1/4" tube and after the leakage rate has stabilized, count the number of bubbles appearing during a 10 second period. (See chart below for allowable leakage rates.)
7. Repeat the same procedure for valve V2 (port 3). (Energize terminal 2 on the DIN connector to open valve 1).

After completing the above tests proceed as follows:

8. Verify that the downstream manual ball valve is closed, and both automatic safety shutoff valves are de-energized.
9. Remove the flexible hose, and close all test nipples.
10. With the upstream manual ball valve open, energize both automatic safety shutoff valves.
11. Use soapy water to leak test all test nipples to ensure that there are no leaks.
12. If no leakage is detected, de-energize all automatic safety shutoff valves, and open the downstream manual ball valve.

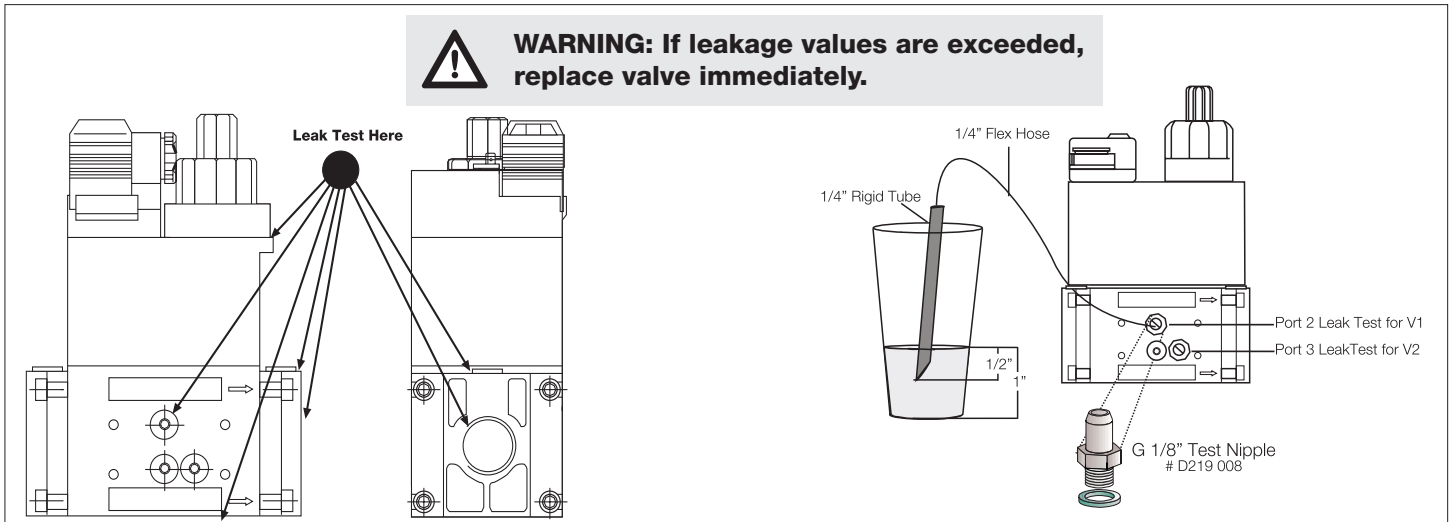

WARNING: If leakage values are exceeded, replace valve immediately.

| Type | Allowable Valve Seat Leakage* for up to 7 PSI inlet | # of Bubbles in 10 sec | | |
|-------------------|--|------------------------|-------------|----|
| | | AIR | Natural Gas | LP |
| DMV D(LE) 701/602 | 239 cc/hr | 5 | 6 | 4 |
| DMV D(LE) 702/602 | 464 cc/hr | 9 | 11 | 7 |
| DMV D(LE) 703/602 | 464 cc/hr | 9 | 11 | 7 |

*Based on air, and test conditions per UL 429 Section 29. (Air or inert gas at a pressure of 1/4 psig and also at a pressure of one and one-half times maximum operating pressure differential, but not less than 1/2 psig. This test shall be applied with the valve installed in its intended position.) Volume of bubble defined in Table 2 of FCI 70-2-1998.

VALVE TEST PORTS

- Ports 1 and 4 are upstream both valves.
- Port 2 is inbetween both valves.
- Ports 3 and 5 are downstream both valves.

The ports are G 1/8 type threads conforming to the standard ISO 228 (fka BSP). The G 1/8 test nipple (# 219-008) can be screwed in any of these pressure tap ports.

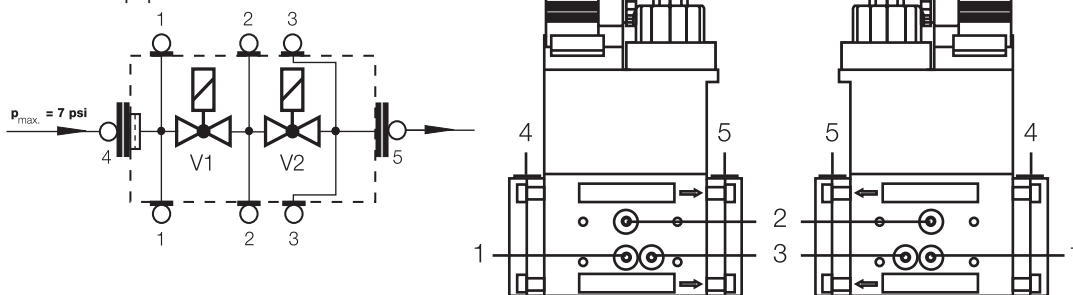

Replacement Coils

| | Mag. Type | Part # for 120Vac | Part # for 24Vac | Part # for 24Vdc |
|--------------------------|-----------|-------------------|------------------|------------------|
| DMV-D(LE) 701/602 | 1111 | 232-401 | 238-554 | 238-829 |
| DMV-D(LE) 702/602 | 1211 | 232-402 | 238-825 | 238-826 |
| DMV-D(LE) 703/602 | 1212 | 232-403 | 238-822 | 238-823 |

Part is an assembly containing both coils, the printed wiring board, the clear (or black) cover and the tan coil housing.

Replacement Printed Wiring Board

| | Part # for 120Vac | Part # for 24Vac | Part # for 24Vdc |
|--------------------------|-------------------|------------------|------------------|
| DMV-D(LE) 701/602 | 238-803 | 238-803 | 238-804 |
| DMV-D(LE) 702/602 | 238-806 | 238-806 | 238-807 |
| DMV-D(LE) 703/602 | 238-806 | 238-806 | 238-807 |

Other Replacement Parts and Accessories

| Accessories/Adapters | P/N |
|--|----------|
| DIN-Electrical Connector (Hirschmann) | 210-319 |
| DIN-Electrical Connector (Burkert) | 246-699 |
| M20 - 1/2" NPT Conduit Adapter | 240-671 |
| Valve switch CPI 400 | 224-253A |
| Visual indicator | 217-665 |
| 1/4" NPT port 1 or port 2 adapter (reduced port) | 225-047 |
| 1/2" NPT port 2 pilot gas adapter (reduced port) | 225-043 |
| G 1/8" Test nipple | 219-008 |
| Port 3 pressure switch mounting adapter | 214-975 |

| Valve Description | Flange | NPT P/N | Rp P/N | Oring and bolt kit P/N* | FRI mounting Kit P/N** | Integral strainer and Filter replacement |
|-------------------|---------------|---------|---------|-------------------------|------------------------|--|
| DMV-701 | 1/2" | 222-371 | 222-341 | 224-093 | 219-967 | 230-440 |
| DMV-701 | 3/4" | 222-368 | 222-342 | 224-093 | 219-967 | 230-440 |
| DMV-701 | 1" | 221-999 | 222-001 | 224-093 | 219-967 | 230-440 |
| DMV-702 & 703 | 1" | 222-369 | 222-343 | 224-094 | 219-968 | 230-441 |
| DMV-702 & 703 | 1 1/4" | 222-370 | 222-344 | 224-094 | 219-968 | 230-441 |
| DMV-702 & 703 | 1 1/2" | 222-003 | 221-884 | 224-094 | 219-968 | 230-441 |
| DMV-702 & 703 | 2" | 221-997 | 221-926 | 224-094 | 219-968 | 230-441 |

* Includes two orings for flanges and two sets of bolts (one set of four bolts for each flange).

** Includes four bolts and one oring.

FLOW CURVE

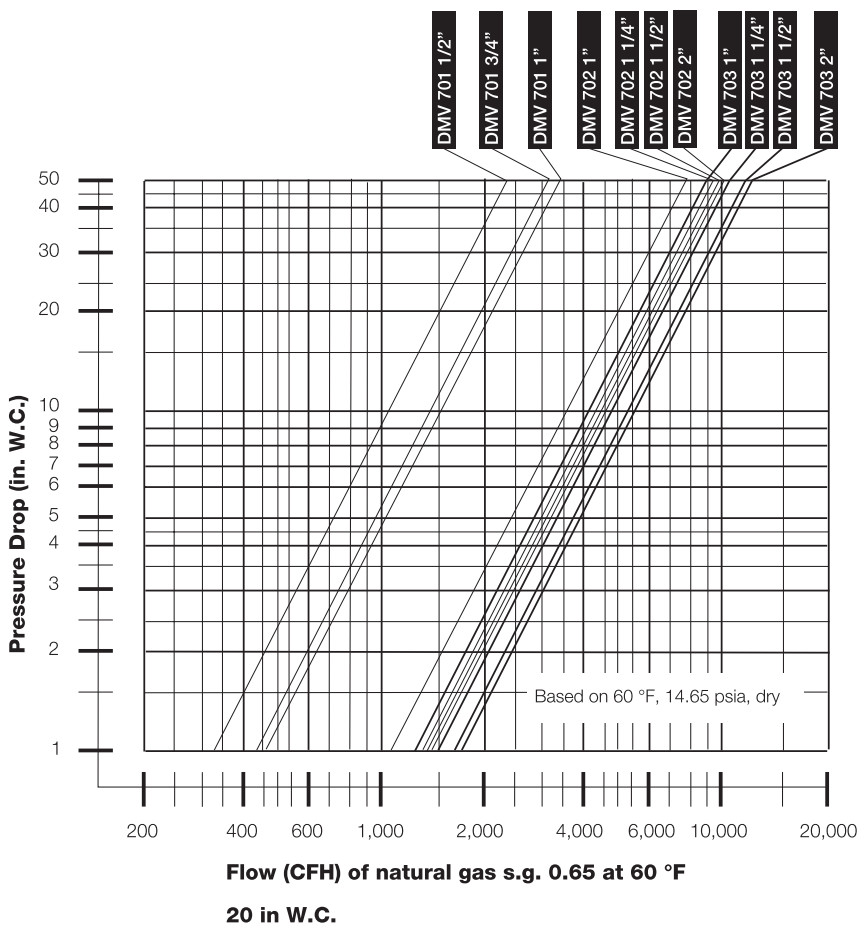

PRESSURE DROP FOR OTHER GASES

To determine the pressure drop when using a gas other than natural gas, use the flow formula below and f value located in the chart below to determine the “corrected” flow rate in CFH through the valve for the other gas used. For example, when using propane, divide the volume (CFH) of propane required for the application by the calculated value f (f = 0.66 for propane). Use this “corrected” flow rate and the flow curve above to determine pressure drop for propane.

$$\dot{V}_{\text{gas used}} = \dot{V}_{\text{Natural Gas}} \times f$$

| Type of gas used | Density [kg/m ³] | sg | f |
|------------------|------------------------------|------|------|
| Natural gas | 0.81 | 0.65 | 1.00 |
| Butane | 2.39 | 1.95 | 0.58 |
| Propane | 1.86 | 1.50 | 0.66 |
| Air | 1.24 | 1.00 | 0.80 |

Use this formula to calculator the f factor for other gases not listed on the table.

$$f = \sqrt{\frac{\text{Spec. gravity of Natural Gas}}{\text{Spec. gravity of gas used}}}$$

RATED CAPACITY

Capacity in CFH at pressure drop of 1 inch water column; natural gas, sp.gr.=0.64

| | 1/2" | 3/4" | 1" | 1-1/4" | 1-1/2" | 2" |
|-------------------|------|------|------|--------|--------|------|
| DMV-D(LE) 701/602 | 345 | 429 | 457 | - | - | - |
| DMV-D(LE) 702/602 | - | - | 1065 | 1277 | 1368 | 1430 |
| DMV-D(LE) 703/602 | - | - | 1230 | 1532 | 1698 | 1795 |