

**DMV-D(LE) 525/11 Threaded & DMV 5.../11 Flanged  
Dual Modular Safety Shutoff Valves  
Installation Instructions**

**SPECIFICATIONS**

**DMV-D** Two normally closed safety shutoff valves in one housing. V1 and V2 are fast opening, fast closing. Adjustable max. flow on V1.

**DMV-DLE** Two normally closed safety shutoff valves in one housing. V1 fast opening, fast closing. V2 slow opening, fast closing valve. Adjustable max. flow V1 and adjustable initial lift with V2.

Body size	Flange Size
DMV-D(LE) 525/11	2" NPT/Rp
DMV-D(LE) 5040/11	1 1/2" ISO Flanged
DMV-D(LE) 5050/11	2" ISO Flanged
DMV-D(LE) 5065/11	2 1/2" ISO Flanged
DMV-D(LE) 5080/11	3" ISO Flanged
DMV-D(LE) 5100/11	4" ISO Flanged
DMV-D(LE) 5125/11	5" ISO Flanged

**Gases**  
Natural gas, propane, butane, air, and other noncorrosive gases. Suitable for dry, 0.1% by volume H<sub>2</sub>S.

**Maximum Operating Pressure**  
7 PSI (500 mbar) FM, CE; 5 PSI (360 mbar) CSA

**Ambient / Fluid Temperature**  
+5°F to +140°F; (-15°C to +60°C)

**Electrical Ratings Available**  
110 to 120 Vac /50 to 60 Hz  
220 to 240 Vac /50 to 60 Hz  
24 Vdc  
24 Vac /50 to 60 Hz

**Power Consumption with all coils energized**

DMV-D(LE) 525/11	110 VA
DMV-D(LE) 5040/11	90 VA
DMV-D(LE) 5050/11	90 VA
DMV-D(LE) 5065/11	110 VA
DMV-D(LE) 5080/11	110 VA
DMV-D(LE) 5100/11	135 VA
DMV-D(LE) 5125/11	200 VA

**Electrical Connection**  
DIN-Connector with 1/2" NPT conduit adapter

**Operating Time**  
100 % duty cycle

**Closing Time (Valve 1 & Valve 2)**  
< 1 second

**Opening Time**  
DMV-D: V1 & V2 < 1 sec.  
DMV-DLE: V1 < 1 sec.; V2 10 to 20 sec. (70 °F)

**Max. Flow Setting (DMV-D & DMV-DLE)**  
Adjustable on V1,  
Valve one: < 5 to 35 % of total flow

**Initial Lift Adjustment (DMV-DLE) only**  
Adjustable on V2 stage one: 0 to 70 % of total flow; 0 to 35% of stroke

**Materials in contact with Gas**  
Housing: Aluminum, Steel; free of nonferrous metals.  
Sealings on valve seats: NBR-based rubber.

**Mounting Position**  
Solenoid upright vertical  
to solenoid horizontal

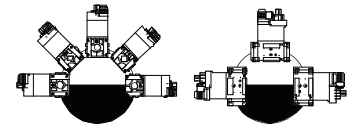

**Strainer**  
23 Mesh, installed in the housing upstream V1

**Test Port**  
Taps available on both sides upstream of V1, between V1 and V2 and downstream of V2, and on both flanges

**Position Indication (optional)**  
Visual Indicator  
CPI 400 with visual indication and electrical switch (SPDT)

**Approvals**  
CSA: Certified File No.101989  
FM Approved: Report 3007653  
Commonwealth of Massachusetts Approved Product  
Approval code G1-1107-35



**ATTENTION**

- Read these instructions carefully.
- Failure to follow them and/or improper installation may cause explosion, property damage and injuries.
- The system must meet all applicable national and local code requirements such as but not limited to NFPA 86, NFPA 37, NFPA 160, ANSI Z83.4/ CSA 3.7, ANSI Z83.18/CSA 4.9, ANSI Z21.13, CSD-1, CAN1-3.1, CGA 3.2, CSA 3.8, CSA B149.1, or CSA B149.3.
- Installation must be done with the supervision of a licensed burner technician.
- Check the ratings in the specifications to make sure that they are suitable for your application.
- Never perform work if gas pressure or power is applied, or in the presence of an open flame.
- Once installed, perform a complete checkout including leak testing.
- Verify proper operation after servicing.

Karl Dungs, Inc

524 Apollo Drive, Suite 10 Lino Lakes, MN 55014 U.S.A.

Phone: (651) 792-8912 Fax: (651) 792-8919 E-mail: info@karldungsusa.com

## PAINTING VALVE

- It is not recommended that this valve be painted. Painting covers date codes and other labels that identifies this valve.
- If the valve needs to be painted, a paint free of volatile organic compounds (VOC's) must be used. VOC's can damage valve orings, resulting in external gas leakage over time.
- During the painting process, use measures that will allow the valve's date code and other labeling information to be legible after the paint is applied.

## PROTECTION FROM RADIANT HEAT

- Radiant heat must be considered as a heat source that could result in an ambient temperature higher than the rating of this valve.
- Provide proper shielding to protect against radiant heat.

## MOUNTING

### DMV 525/11 Mounting Procedure

- Remove the 8 bolts that are holding the protective covers on the inlet and outlet of the DMV using a 13 mm wrench.
- Remove the two protective covers from the DMV-D(LE) body.
- Verify that the O-rings and the grooves are clean and in good condition. Clean if necessary.
- Attach the flanges using the bolts supplied.
- Use the arrow on the body to confirm that the valve is mounted in the correct flow direction.

 If the flow is not in the same direction of the arrows the valves will not operate properly.

- Tighten the bolts in a crisscross pattern.
- Do not overtighten the bolts. Follow the maximum torque values below.

### Recommended Torque on Bolts

M8	Bolt Size
130	[lb-in]

- Install the valve with the gas flow matching the direction indicated by the arrows on the casting.
- Mount the DMV 525/11 with the solenoid vertical or horizontal.
- Use new, properly reamed and NPT threaded pipe free of chips.
- Apply good quality pipe sealant, putting a moderate amount on the male threads only. If using LP gas, use pipe sealant rated for use with LP gas.
- Do not thread pipe too far. DMV 525/11 distortion and/or malfunction may result from excess pipe in the valve body.
- Apply counter pressure with a parallel jaw wrench only to the flats of the DMV 525/11 when installing pipe.
- Do not overtighten the pipe. Follow the maximum torque values listed.

### Recommended Torque for Piping

2"	NPT Pipe
1190	[lb-in]

- After installation is complete, perform a leak test.

### DMV 5.../11 Flanged Mounting Procedure

- Install the DMV 5.../11 with the gas flow matching the direction indicated by the arrows on the casting.

- Mount the DMV 5.../11 with the solenoid vertical to horizontal.
- Insert seal.
- Insert bolts, tighten in a star pattern to ensure uniform tightness.
- Do not overtighten bolts. Follow the maximum torque values listed.

### Recommended Torque for Bolts

Bolt	M16 (DIN 939)
------	---------------

$T_{MAX}$	443	[lb-in]
-----------	-----	---------

- After installation is complete, perform a leak test.

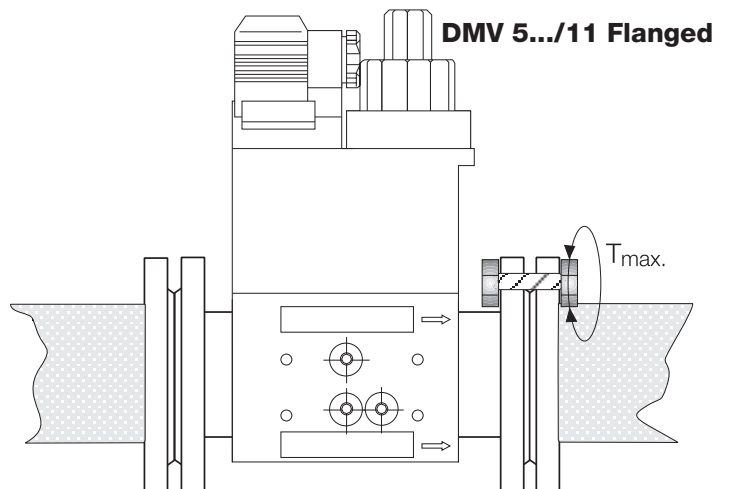
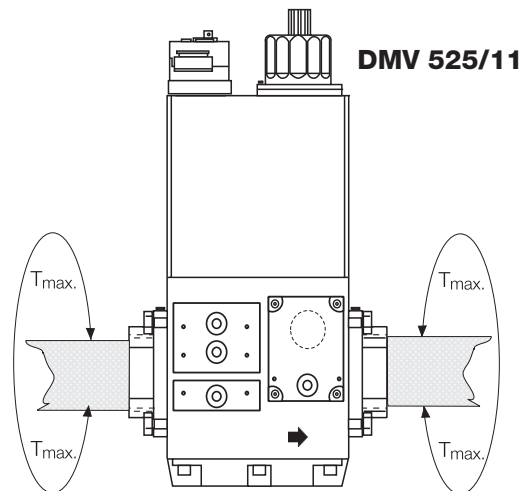

## WIRING

- Disconnect all power to the valves before wiring to prevent electrical shock and equipment damage.
- Do not exceed the electrical ratings given in the specifications and on the valve.
- Attach a flexible 1/2" NPT conduit to the DIN connector.
- Route the wires through the conduit and the DIN connector.
- Use 14 or 16 gauge wire for at least 75°C (167°F).
- Connect the wiring to the appropriate screw terminals in the DIN connector.
- Plug the DIN connector into the AMP terminals. Fasten the DIN connector with the screw supplied.



**CAUTION:** All wiring must comply with local electrical codes, ordinances and regulations.

### DIN Connector screw terminal connections

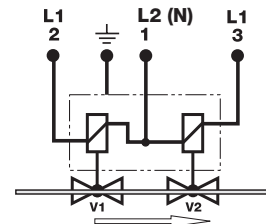
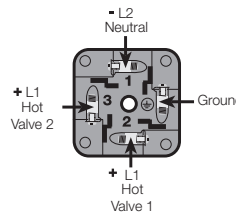

## VALVE ADJUSTMENT

### Flow Setting DMV 525/11 & DMV 5.../11 Flanged

- The valves are factory set with the flow adjustment fully open.
- **CAUTION:** Make sure the flow of gas does not create a hazard.
- The flow adjustment is on top of valve 1, under the black flap.
- Use a slotted screwdriver to turn the flow setting. Turn clockwise for less gas or counterclockwise for more gas.
- Check the flow at the burner with an orifice or flow meter.
- Replace the black flap.

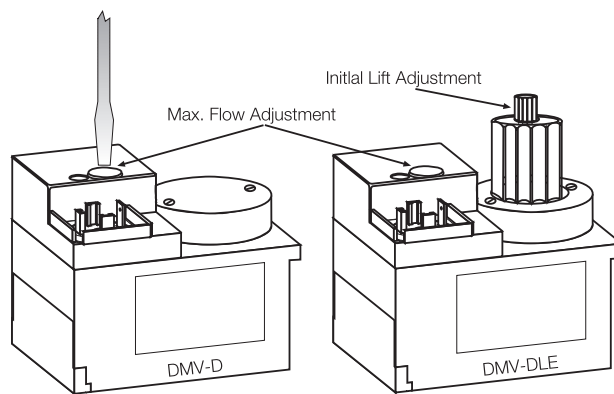

**CAUTION:** Do not adjust or remove any screws or bolts which are sealed with a Red or Blue colored compound. Doing so will void all approvals and warranties.

### Initial Lift Adjustment (DMV-DLE only)

The initial lift adjustment varies the initial gas flow through the valve as the valve seat begins to open. This adjustment can vary the initial flow between 0 % and 70% of the total gas flow; 0 to 25% of stroke. All DMV-DLE valves are factory set with no initial lift. To adjust the lift proceed as follows:

- Unscrew the small black cap on top of the silver hydraulic brake to expose the initial lift adjustment knob.
- The black cap also serves as tool; turn the cap over and insert it on the slot on the adjustment knob.
- Turn the knob clockwise for a min. initial lift or counterclockwise for a max. initial lift.
- Once the desired initial fast lift has been achieved, reinstall the black cap.

Initial Lift Opening Curve

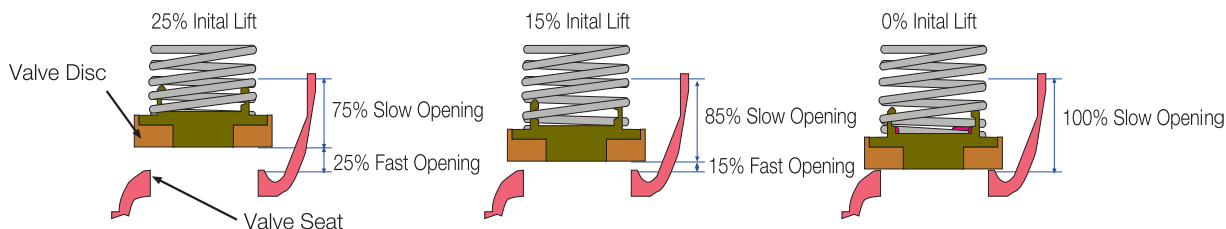
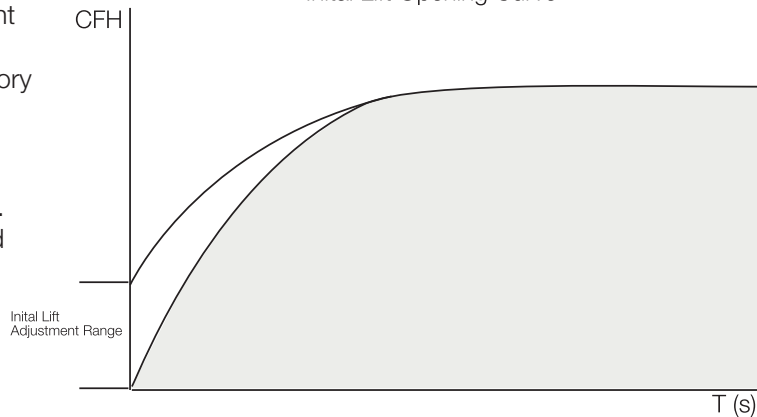

# SIDE TAPS

## DMV 525/11 Side Taps

## DMV 5.../11 Flanged Side Taps

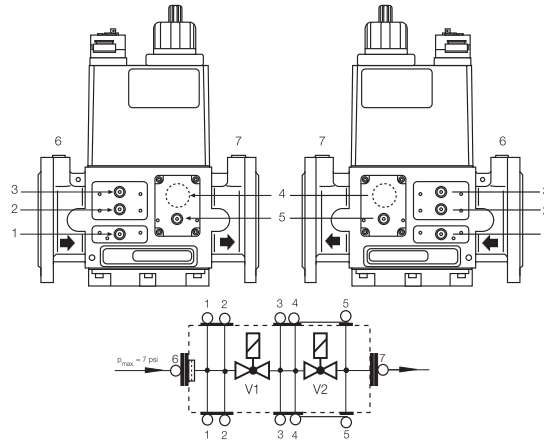
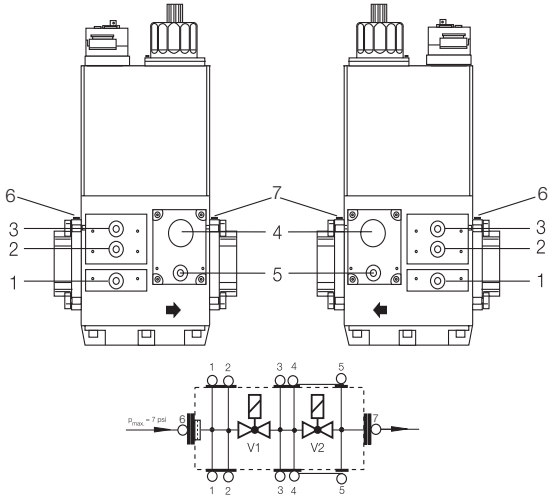

### DMV 5.../11 Flange Accessories

Size	*Weld neck part #	# of Holes	Bolt size	**Bolt part #	***Seal part #
DN 40	227-137	4	M16x55	135-940	100-164
DN 50	227-138	4	M16x55	135-940	030-221
DN 65	227-139	4	M16x65	135-930	099-408
DN 80	227-140	8	M16x65	135-930	030-254
DN 100	227-141	8	M16x65	135-930	030-304
DN 125	227-142	8	M16x75	148-830	030-312
DN 65 to 2 1/2"NPT	243-690	4	M16x65	135-930	099-408
DN 80 to 3"NPT	243-219	8	M16x65	135-930	030-254

\*When a control is used alone, one mating flange is needed for each end, for a total of two flanges.

When one control is bolted to another, such as an FRS to a DMV, one mating flange is needed for each end, for a total of two flanges

\*\* includes one bolt, one lock washer, and one nut

\*\*\* one seal needed for each flange

## VALVE LEAKAGE TEST

This leak test procedure tests the external sealing and valve seat sealing capabilities of the DMV automatic safety shutoff valve. Only qualified personnel should perform this test.

It is required that this test be done on the initial system start-up, and then repeated at least annually. Possibly more often depending on the application, environmental parameters, and the requirements of the authority having jurisdiction.

### SETUP

This test requires the following:

- A) Test nipples installed in the downstream pressure tap port of each automatic safety shutoff valve to make the required 1/4" hose connection in step 4.
- B) A transparent glass of water filled at least 1 inch from the bottom.
- C) A proper leak test tube. An aluminum or copper 1/4" rigid tube with a 45° cut at the end that is then connected to a 1/4" flexible hose of some convenient length provides for a more accurate leakage measurement. However, a 45° cut at the end of the 1/4" flexible hose will suffice, but it will not likely be as accurate as the rigid tube.
- D) For detecting external leakages, an all purpose liquid leak detector solution or a soapy water solution is required.

### LEAK TEST PROCEDURE

Use the illustration below as a reference.

1. With the upstream ball valve open, the downstream ball valve closed and both valves energized, apply an all purpose liquid leak detector solution to the "External Leakage Test Areas" indicated in the illustration below, to any accessories mounted to the safety valve, and to all gas piping and gas components downstream the equipment isolation valve, and the inlet and outlet gas piping of the automatic safety shutoff valve. The presence of bubbles indicates a leak, which needs to be rectified before proceeding.
2. Then, de-energize the burner system and verify that both automatic safety shutoff valves are closed.
3. Close the upstream and downstream manual ball valve.
4. Using a screwdriver, slowly open the V1 test nipple (port 3) by turning it counter clockwise to depressurize the volume between the two valves, and connect the 1/4" flexible hose to the test nipple.
5. Slowly open the upstream manual ball valve, and then provide for some time to allow potential leakage to charge the test chamber before measuring the valve seat leakage.

6. Immerse the 1/4 in. tube vertically 1/2 in. (12.7 mm) below the water surface. If bubbles emerge from the 1/4" tube and after the leakage rate has stabilized, count the number of bubbles appearing during a 10 second period. (See chart below for allowable leakage rates.)
7. Repeat the same procedure for valve V2 (port 5), except that valve #1 needs to be opened. (Energize only terminal 2 on the DIN connector to open valve 1). After completing the above tests proceed as follows:
8. Verify that the downstream manual ball valve is closed, and both automatic safety shutoff valves are de-energized.
9. Remove the flexible hose, and close all test nipples.
10. With the upstream manual ball valve open, energize both automatic safety shutoff valves.
11. Use soapy water to leak test all test nipples to ensure that there are no leaks.
12. If no leakage is detected, de-energize all automatic safety shutoff valves, and open the downstream manual ball valve.

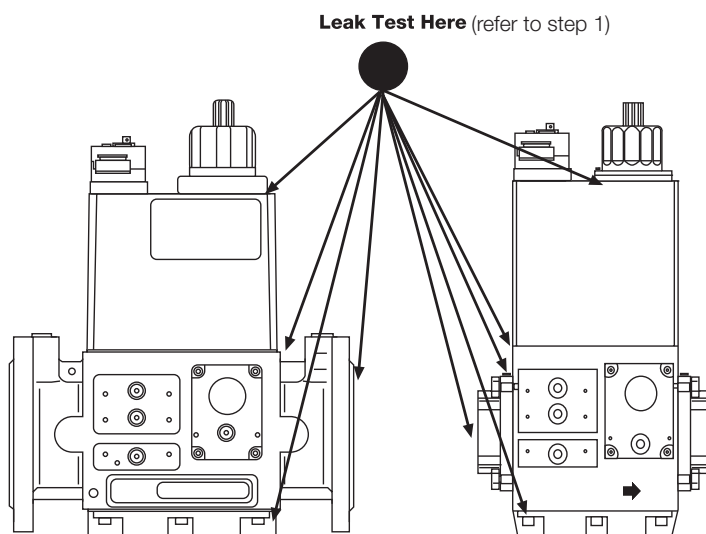

**WARNING:** If leakage values are exceeded, replace valve immediately.

Valve Type	Allowable Valve Seat Leakage* up to 7 PSI inlet	# of Bubbles in 10 sec		
		AIR	Natural Gas	LP
DMV D(LE) 525/11	464 cc/hr	9	11	7
DMV D(LE) 5040	464 cc/hr	9	11	7
DMV D(LE) 5050	464 cc/hr	9	11	7
DMV D(LE) 5065	633 cc/hr	11	13	10
DMV D(LE) 5080	790 cc/hr	13	17	11
DMV D(LE) 5100	934 cc/hr	17	22	15
DMV D(LE) 5125	1156 cc/hr	22	27	18

\*Based on air, and test conditions per UL 429 Section 29. (Air or inert gas at a pressure of 1/4 psig and also at a pressure of one and one-half times maximum operating pressure differential, but not less than 1/2 psig. This test shall be applied with the valve installed in its intended position.) Volume of bubble defined in Table 2 of FCI 70-2-1998.

## FLOW CURVE

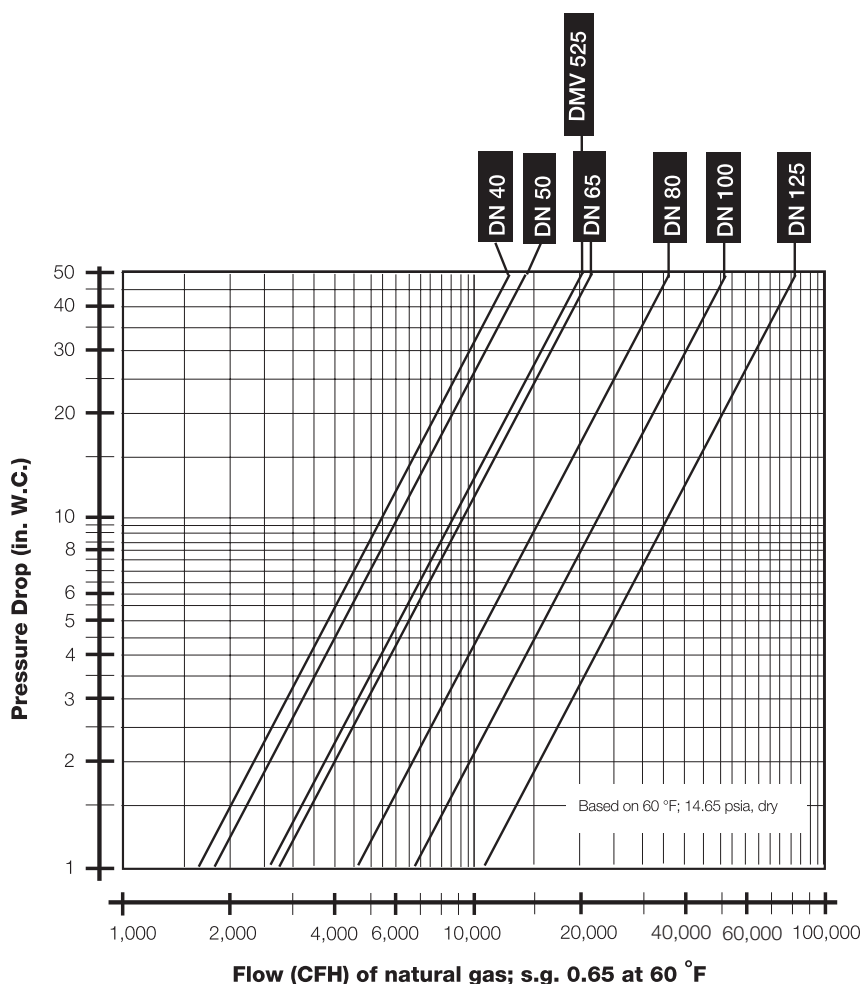

## REPLACEMENT PARTS

Valve Type	Mag. Type	Replacement Coils Part # for 120Vac	Replacement Coils Part # for 24Vdc	Replacement PWB Part # for 120Vac	Replacement PWB Part # for 24Vdc
<b>DMV-D(LE) 525</b>	1411	225-168	225-170	250-379A	225-381A
<b>DMV-D(LE) 5040</b>	1212	225-049	225-051	225-379A	225-381A
<b>DMV-D(LE) 5050</b>	1212	225-049	225-051	225-379A	225-381A
<b>DMV-D(LE) 5065</b>	1411	225-168	225-170	225-379A	225-381A
<b>DMV-D(LE) 5080</b>	1511	225-217	225-219	225-379A	225-381A
<b>DMV-D(LE) 5100</b>	1611	225-222	225-224	225-380A	225-381A
<b>DMV-D(LE) 5125</b>	1711	225-226	225-228	225-380A	225-381A

Description	Part #
<b>Electrical DIN Connector</b>	210-319
<b>PG 11-1/2 NPT Adapter</b>	220-566
<b>M20- 1/2 NPT Adapter</b>	249-671
<b>Visual Indicator</b>	217-665
<b>CPI 400 valve switch</b>	224-253A
<b>DMV-D(LE) 525 gasket for flange</b>	231-574
<b>Vent Line Adapter - 1" NPT</b>	243-760