

Dual Modular Safety Shutoff Valve with NEMA 4x Enclosure

**DMV-D/604L Series
DMV-DLE/604L Series**

DUNGS®
Combustion Controls



Two normally closed automatic shutoff valves in one housing; each with the following approvals.

UL Listed

- UL 429
- File # MH 16727

CSA Certified

- ANSI Z21.21 • CSA 6.5
- Marked C/I
- File # 1010989

FM Approved

- Class 7411
- File # 3006982/J.I. IZ 6A0.AF

Commonwealth of Massachusetts Approved Product

- Approval code G1-1107-35
- Gas Safety Shutoff Valve

US & Canadian Models

- DMV-D 702/604, 703/604
- DMV-DLE 702/6, 703/604
- 1 in. NPT - 2 in. NPT
- Rp1 - Rp2

Codes and Standards:

This product is intended for installations covered by but not limited to NFPA 86, ANSI Z83.4, ANSI Z83.18, ANSI Z21.13, UL 795, CSD-1, or CSA B149.3.

DUNGS is an ISO 9001 manufacturing facility.



Description

The Dual Modular Valve (DMV) combines two automatic shutoff valves in one compact housing, which can be wired independently or in parallel.

Valve 1 (V1) of the DMV-D and DMV-DLE series is fast opening and fast closing. Valve 2 (V2) of the DMV-D is fast opening, while V2 of the DMV-DLE is slow-opening for smoother light-off. Max. flow adjustment on V2 provides variable main flow on both models.

Internal profiles and compact design optimize flow and provide a low pressure drop. Three body styles reduce inventory.

Directly mounting the following accessories creates a compact valve train without additional piping:

- Pressure regulator
- High and low gas pressure switches
- Valve proving system
- Vent line adapter
- Butterfly control valve

Application

The DMV/604L is recommended for industrial and commercial heating applications that require two safety shutoff valves. The DMV is suitable for natural gas, propane, butane, air and other inert gases.

DMV-D.../604L Two normally closed safety shutoff valves in one housing. V1 and V2 are fast opening, fast closing. Adjustable max flow with V2.

DMV-DLE.../604L Two normally closed safety shutoff valves in one housing. V1 fast opening, fast closing. V2 is slow opening, fast closing. Adjustable max flow and Adjustable initial lift with V2.

Specifications

Body sizes pipe size / thread	DMV 702 1" - 2" NPT or Rp	DMV 703 1" - 2" NPT or Rp
Max. operating pressure	7 PSI (500 mbar) UL, FM	5 PSI (360 mbar) CSA
Max. body pressure	15 PSI (1000 mbar)	
Max. close-off pressure	7 PSI (500 mbar) UL, FM	5 PSI (360 mbar) CSA
Electrical ratings (+10% / -15%)	110 - 120 Vac / 50 - 60 Hz 24 Vac / 50 - 60 Hz; 24 Vdc	
Power ratings	DMV 702: 30 VA	DMV 703: 40VA
	Ratings shown are total power consumption for each coil. Inrush and full load current have the same VA rating.	
Enclosure rating	NEMA Type 4x	
Electrical connection	Screw terminals with 1/2" NPT conduit connection	
Operating time	100 % duty cycle	
Closing time	< 1 s	
Opening time (to max. flow)	DMV-D.../604 DMV-DLE.../604	V1 & V2 < 1 s V1 < 1 s; V2 Adjustable to approx. 10 to 20 s at 70 °F
Initial lift adjustment	Adjustable on V2	DLE only; 0 to 70 % of total flow; 0 to 25% of stroke
Max. flow adjustment	Adjustable on V2	<10 to 100 % of total flow; <10 to 100% of stroke
Materials in contact with gas	Housing: Sealings on valve seats:	Aluminium, Steel. NBR-based rubber
Ambient temperature rating	-20 °F to +150 °F (-30 °C to +65 °C)	
Installation position	Safety valve upright vertical to horizontal	
Test ports / Pressure switch mounting ports	G 1/8 ISO 228 ports available on both sides. Each side has one port upstream V1, one between V1 and V2, one downstream V2, and one on each flange.	
Gas filter (optional)	Replaceable integral gas filter (50 micron) in inlet of DMV or Pre-Mount Filter Block for DMV 702 and 703. (Cannot be used with FRI directly mounted to the DMV.)	
Gas strainer (standard)	Installed in the housing upstream V1 (23 mesh)	
Position indication (order separately)	CPI 400 with indication lamps and SPDT interlock switch or Visual indicator (VI)	
Valve proving system	Requires VPS 504; mounts directly to either side of DMV. (Only available in NEMA Type 12 enclosure.)	

DMV dual safety shutoff valve modular system

Optional mounting system shown,
other configurations possible

DMV dual safety shutoff valve with upstream FRI pressure regulator

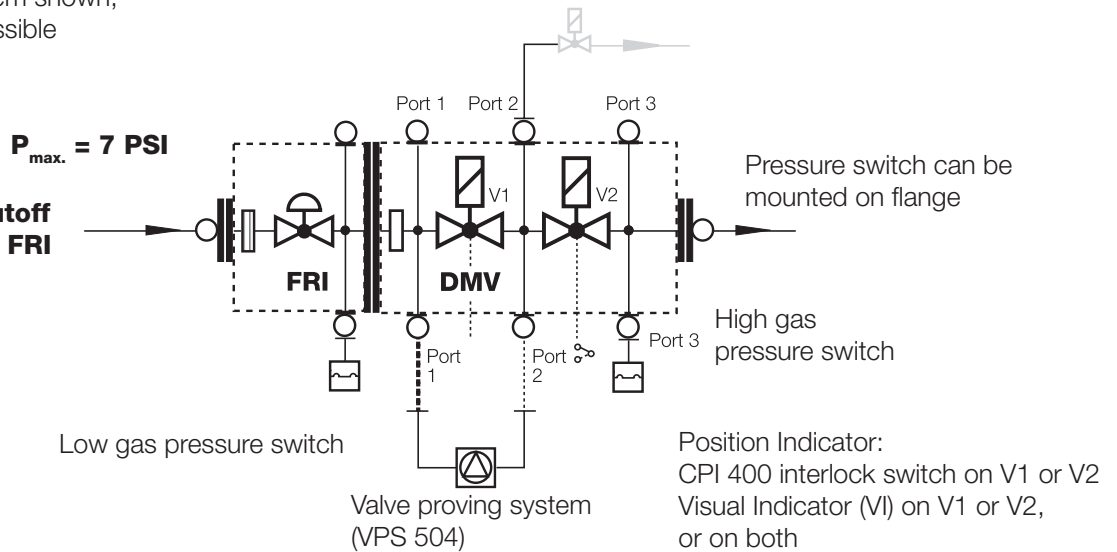

DMV dual safety shutoff valve with downstream FRI pressure regulator

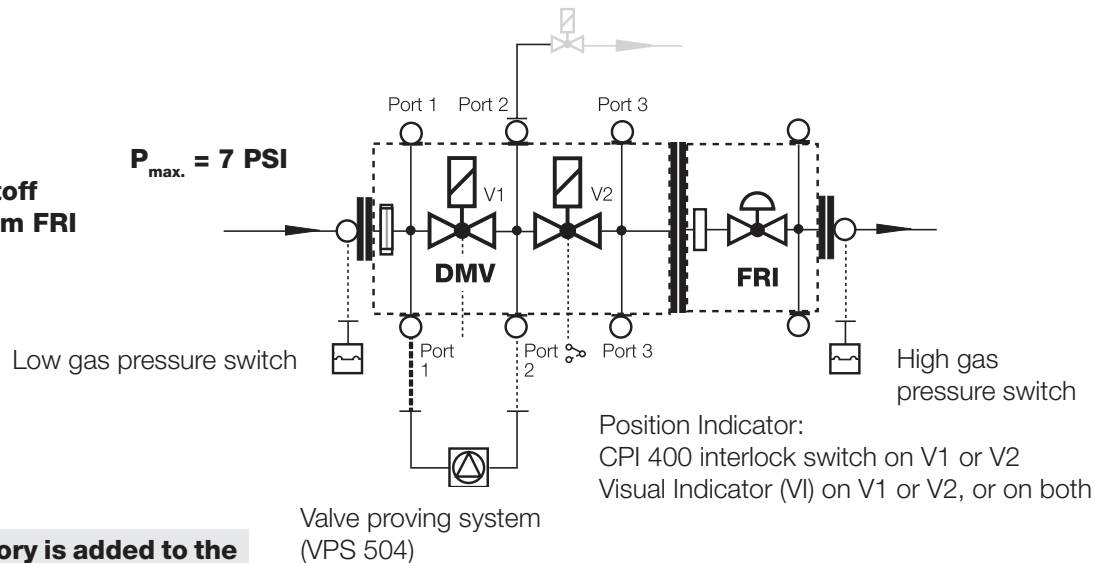

When an accessory is added to the DMV, it might not be possible to mount other devices.

FRI Gas pressure regulator

Mounting the FRI series gas pressure regulator directly to the DMV dual safety shutoff valve is possible with a mounting kit.

The FRI pressure regulator can be installed upstream or downstream of the DMV dual safety shutoff valve depending on application requirements.

FRI mounting kit for DMV

FRI 710-712/6 to DMV 702/6 + 703/6

Order No. 219-968

Additional Accessories

VPS 504

Valve proving system (approved by some authorities having jurisdiction in lieu of vent valve and "proof of closure" e.g. FM and Swiss Re). NOTE: The VPS is a NEMA type 12 enclosure.

DMK butterfly control valve

Mounts directly downstream of DMV to modulate gas flow. Requires actuator. Use DMA actuator with DMK butterfly valve.

Integral gas filter (optional)

50 micron gas filter

Pre-Mount Filter (optional)

50 micron gas filter

Adapters

- 1/4" NPT adapter (225-047)
- 1/2" NPT Pilot gas adapter; Check flow requirements. (225-043)
- G 1/8" Test nipple (219-008)
- Port 3 Pressure switch mounting adapter (214-975)

DMV D(LE) 7xx/604L VLA (with vent line adapter)

Factory installed vent line adapter which integrates a vent line connection with the DMV series.

GAO/GMH/GML A2 pressure switch

Position indication

CPI 400 with indication lamps and SPDT interlock switch, or Visual Indicator (VI).

Dimensions inch (mm)

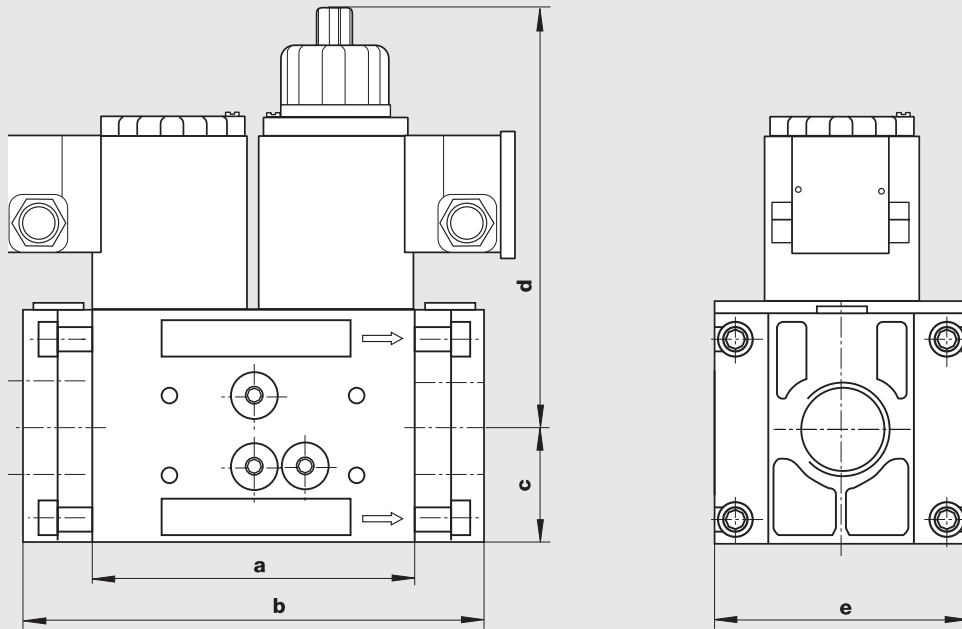

Type	110-120 VAC 50-60 Hz Order No.	Power* [VA]	Dimensions [inch]					Weight [lbs] [kg]
			a	b**	c***	d	e	
DMV-D 702/604L	240-610	30	4.9	6.9 / 8.1	1.8	5.9	3.9	10.1
			124	174 / 206	45	150	101	4.6
DMV-D 703/604L	241-436	40	4.9	6.9 / 8.1	1.8	7.5	3.9	12.1
			124	175 / 206	45	190	101	5.6
DMV-DLE 702/604L	240-805	30	4.9	6.9 / 8.1	1.8	6.7	3.9	10.3
			124	174 / 206	45	197	101	4.7
DMV-DLE 703/604L	241-435	40	4.9	6.9 / 8.1	1.8	8.6	3.9	12.3
			124	174 / 206	45	218	101	5.7

* Inrush current and full load current have the same VA rating.

** DMV 702/703 with 1" or 1 - 1/4" flange: 6.9" / DMV 702/703 with 1 - 1/2" or 2" flange: 8.1"

*** When using with the vent line adapter assembly, add 1.65" to dimension c. (see vent line adapter information sheet)

Valve	Flange	NPT	Rp	CPI 400 Visual indicator	224-253A 217-665
DMV-702/604L & 703/604L	1"	222-369	222-343		
DMV-702/604L & 703/604L	1 1/4"	222-370	222-344		
DMV-702/604L & 703/604L	1 1/2"	222-003	221-884		
DMV-702/604L & 703/604L	2"	221-997	221-926		

Integral gas filter (50 micron) and strainer

DMV-702/604L 230-441

DMV-703/604L 230-441

Replacement Coils (120Vac)

DMV-702/604L 246-515

DMV-703/604L 246-516

Replacement Hydraulic Brake for DLE versions

240-458



Order flanges, position indicators and gas filters separately.

DMV-D(LE).../604L
sectional drawing

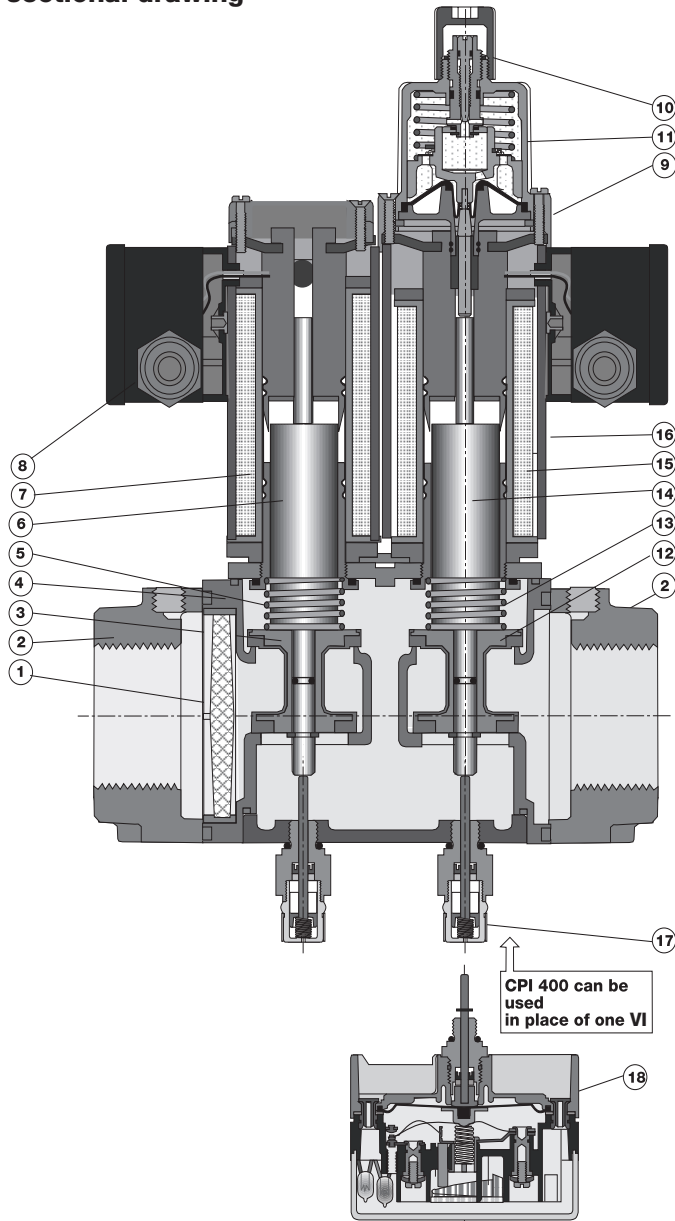

- 1 Strainer
- 2 Flange
- 3 Valve V1
- 4 Housing
- 5 Closing spring V1
- 6 Plunger V1
- 7 Solenoid V1
- 8 Electrical connection
- 9 Max flow adjustment
- 10 Initial lift adjustment (DMV-DLE)
- 11 Hydraulic brake (DMV-DLE)
- 12 Valve V2
- 13 Closing spring V2
- 14 Plunger V2
- 15 Solenoid V2
- 16 Solenoid housing
- 17 Visual indicator (VI)
- 18 CPI 400 interlock switch

To determine the pressure drop when using a gas other than natural gas, use the flow formula below and f value located in the chart below to determine the "corrected" flow rate in CFH through the valve for the other gas used. For example, when using propane, divide the volume (CFH) of propane required for the application by the calculated value f (f = 0.66 for propane). Use this "corrected" flow rate and the flow curve on the next page to determine pressure drop for propane.

$$\dot{V}_{\text{gas used}} = \dot{V}_{\text{Natural Gas}} \times f$$

f = correction factor to determine flow through valves with other gases.

$$f = \sqrt{\frac{\text{Spec. gravity of Natural Gas}}{\text{Spec. gravity of gas used}}}$$

Type of gas	Density [kg/m³]	sg	f
Natural gas	0.81	0.65	1.00
Butane	2.39	1.95	0.58
Propane	1.86	1.50	0.66
Air	1.24	1.00	0.80

**Dual Modular Valve
with NEMA Type 4x Enclosure
DMV-D/604L Series
DMV-DLE/604L Series**



Flow curve

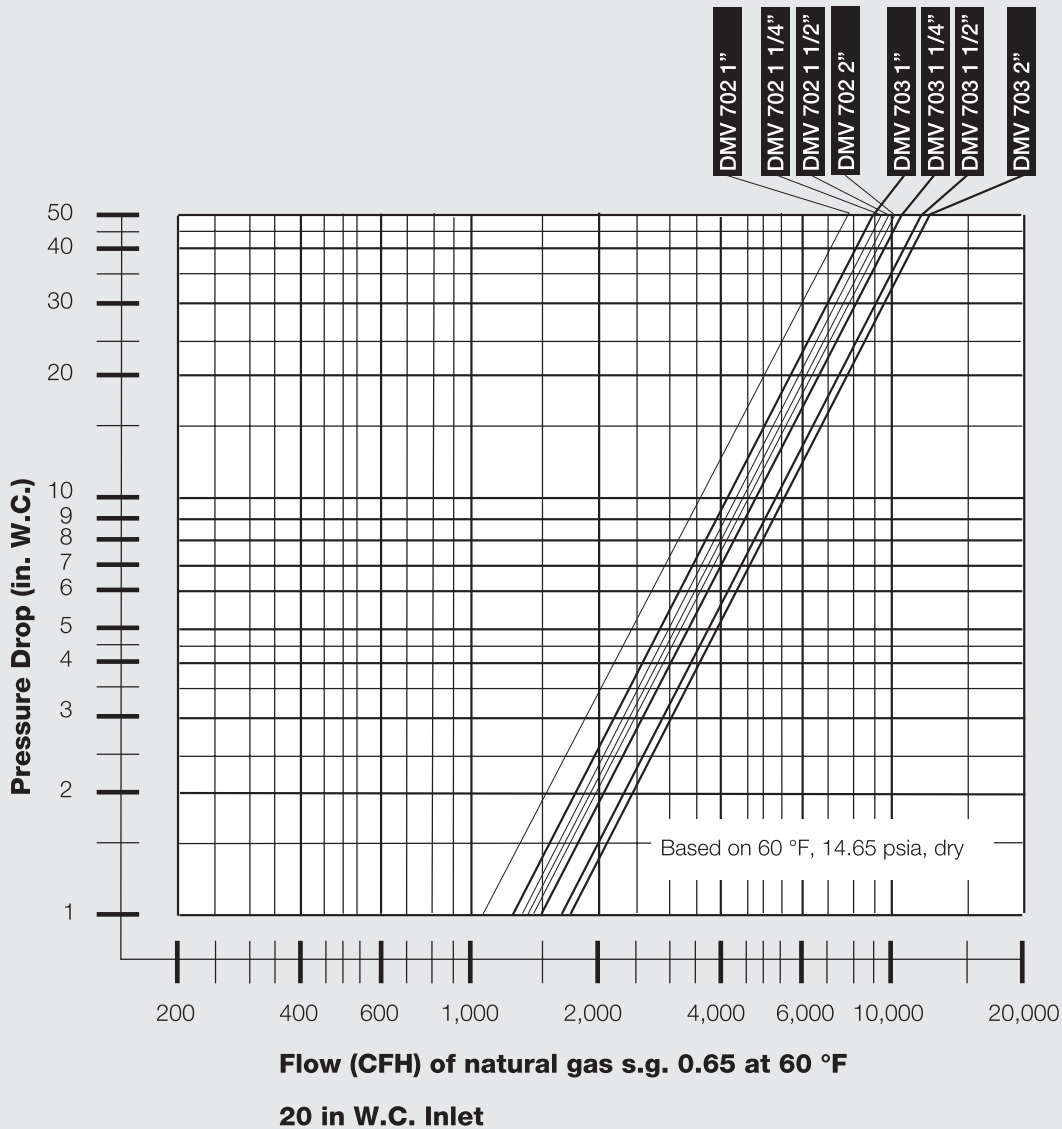

We reserve the right to make any changes in the interest of technical progress.

Karl Dungs Inc.
524 Apollo Drive Suite 10
Lino Lakes, MN 55014, U.S.A.
Phone 651 792-8912
Fax 651 792-8919
e-mail info@karldungsusa.com
Internet <http://www.dungs.com/usa>

Karl Dungs GmbH & Co. KG
P.O. Box 12 29
D-73602 Schorndorf
Phone +49 (0)7181-804-0
Fax +49 (0)7181-804-166
e-mail info@dungs.com
Internet <http://www.dungs.com>