

# Dual Modular Safety Shutoff Valves with Two-stage operation and Proof of Closure DMV-ZRD/612 Series DMV-ZRDLE/612 Series

**DUNGS**<sup>®</sup>  
Combustion Controls



**Two normally closed automatic shutoff valves in one housing. Valve 1 (V1) incorporates proof of closure. Each valve has the following approvals.**

#### UL Recognized

- UL 429
- File #MH16727

#### CSA Certified

- ANSI Z21.21 • CSA 6.5
- Marked C/I
- File # 1010989

#### FM Approved

- Class 7411
- File # J.I. 3017969

#### Commonwealth of Massachusetts Approved Product

- Approval code G1-1107-35
- Gas Safety Shutoff Valve

#### US and Canadian Models

- DMV-ZRD 702/612 and 703/612
- DMV-ZRDLE 702/612 and 703/612

#### Codes and Standards:

This product is intended for installations covered by but not limited to NFPA 86, ANSI Z83.4, ANSI Z83.18, ANSI Z21.13, UL 795, CSD-1, or CSA B149.3.

**DUNGS is an ISO 9001  
manufacturing facility.**

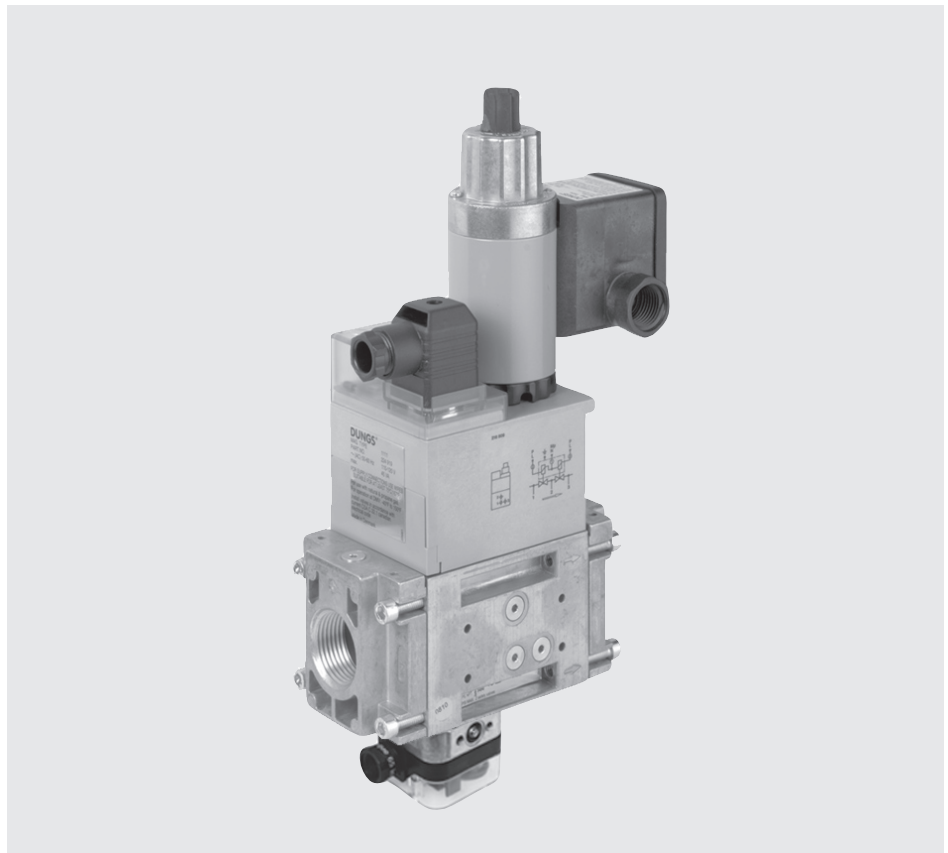

#### Description

The Two-Stage Dual Modular Valve DMV-ZR/612 series combines two safety shutoff valves in one compact housing. Valve 2 incorporates two stages, which can be set at two different firing rates. Both firing rates are field adjustable and can modulate from high to low during burner operation.

Valve 1 (V1) of the DMV-ZRD and DMV-ZRDLE series is fast opening and fast closing. Valve 2 (V2) of the DMV-ZRD is fast opening, while V2 of the DMV-ZRDLE is slow-opening for smoother light-off. Max. flow adjustment on V2 provides variable main flow on both models.

Internal profiles and compact design optimize flow and provide a low pres-

sure drop. Three body styles reduce inventory.

Directly mounting the following accessories creates a compact valve train without additional piping: pressure regulator, high and low gas pressure switches, valve proving system, and vent line adapter.

#### Application

The DMV-ZR is recommended for industrial and commercial heating applications, where two automatic shutoff valves, proof of closure and modulating between two firing rates during burner operation are required. The DMV-ZR Dual Modular Valve two stage is suitable for natural gas, propane, butane, air and inert gases.

**DMV-ZRD/612**

Two normally closed automatic shutoff valves in one housing. Valve 1 (V1) incorporates proof of closure. V1 and V2 are fast opening, fast closing. Adjustable max flow with V2.

**DMV-ZRDLE/612**

Two normally closed automatic shutoff valves in one housing. Valve 1 (V1) incorporates proof of closure. V1 fast opening, fast closing. V2 is slow opening, fast closing. Adjustable max flow and Adjustable initial lift with V2.

**Specifications**

Body sizes pipe size / thread	DMV 701/612 1/2" - 1" NPT	DMV 702/612 1" - 2" NPT	DMV 703/612 1" - 2" NPT
Max. operating pressure	7 PSI (500 mbar) FM, UL		5 PSI (360 mbar) CSA
Max. body pressure	15 PSI (1000 mbar)		
Max. close-off pressure	10 PSI (500 mbar)		
Electrical ratings (+10% / -15%)	110 - 120 VAC/50 - 60 Hz		
Power ratings	DMV 701: 70 VA	DMV 702: 85 VA	DMV 703: 115 VA
	Ratings shown are total power consumption for both valves inclusive. Inrush and full load current have the same VA rating.		
Enclosure rating	NEMA Type 12		
Electrical connection	DIN-connector with 1/2" NPT conduit adapter for valve 1 and valve 2, stage one. Screw terminals with 1/2" NPT conduit connection for valve 2, stage two. Use moisture-resistant No. 14 wire suitable for at least 194 °F (90 °C)		
Operating time	< 1 s @ 100 % duty cycle		
Closing time	DMV-ZRD DMV-ZRDLE	V1 & V2 < 1 s V1 < 1s; V2 Adjustable to approx. 10-20s at 70 °F	
Opening time (to max. flow)	Adjustable on V2		
Initial lift adjustment	DLE only; approx. 0 to 70 % of total flow		
Max. flow adjustment	Adjustable on V2, stage 1: approx. 5 to 30 % of stroke Adjustable on V2, stage 2: approx. 20 to 100 % of stroke		
Materials in contact with gas	Housing: Aluminium, Steel Sealings on valve seats: NBR-based rubber		
Ambient temperature rating	-20 °F to +150 °F (-30 °C to +65 °C)		
Installation position	Safety valve upright vertical to horizontal		
Test ports / Pressure switch mounting ports	G 1/8 ISO 228 ports available on both sides. Each side has one port upstream V1, one between V1 and V2, one downstream V2, and one on each flange.		
Gas filter (optional)	Replaceable integral gas filter (50 micron) in inlet of DMV.		
Gas strainer (standard)	Installed in the housing upstream V1 (23 mesh)		
Proof of closure switch (factory mounted and calibrated on V1)	SPDT switch with position indication lamps; AC max. 10A resistive @ 120 Vac and AC max. 8A inductive @ 120 Vac		
Position indication (mechanical)	Visual indicator (VI), optional for valve #2		
Valve proving system (optional)	Model VPS 504 S06; mounts directly to either side of DMV.		

## Electrical connection

Use moisture-resistant No. 14 wire suitable for at least 194 °F (90 °C)

### DIN Connector screw terminal connections

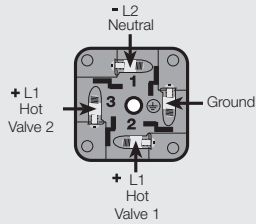

Valves V1, V2 stage 1

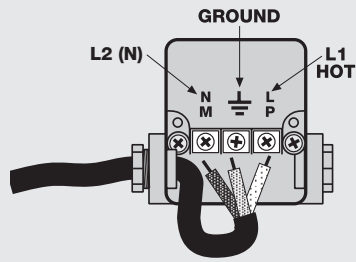

Valve V2 stage 2

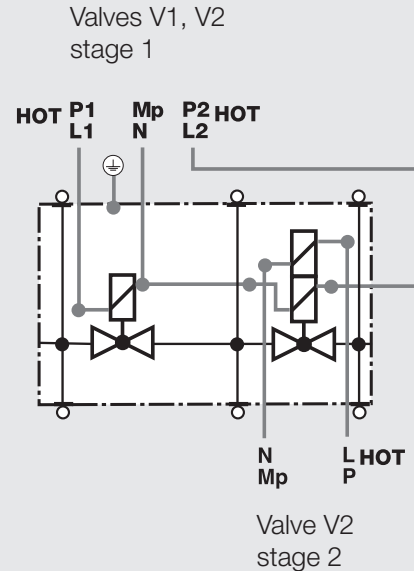

Valves V1, V2 stage 1

Valve V2 stage 2

## Opening behavior DMV-ZRD(LE)

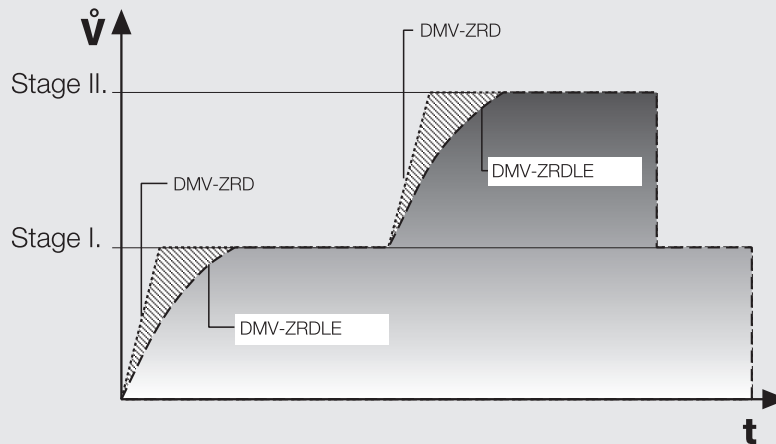

### FRI Gas pressure regulator

Mounting the FRI series gas pressure regulator directly to the DMV dual safety shutoff valve is possible with a mounting kit.

The FRI pressure regulator can be installed upstream or downstream of the DMV dual safety shutoff valve depending on application requirements.

### FRI mounting kit for DMV

FRI 705 - 707/6 to DMV 701  
Order No. 219-967

FRI 710-712/6 to DMV 702 + DMV 703  
Order No. 219-968

### Optional Accessories

#### VPS 504

Valve proving system (approved by some authorities having jurisdiction in lieu of vent valve and "proof of closure" e.g. FM, IRI).

#### Integral gas filter

50 micron gas filter

#### Pre-Mount Filter

50 micron gas filter

#### GAO/GMH/GML A2

gas pressure switch

#### Position indication

Visual indicator (VI)

### Vent Line Adapter

Factory installed vent line adapter which allows the routing of a normally open vent valve and a vent line connection between both safety shutoff valves.

### Adapters

- 1/4" NPT adapter (225-047)
- 1/2" NPT Pilot gas adapter; Check flow requirements. (225-043)
- G 1/8" Test nipple (219-008)
- Port 3 Pressure switch mounting adapter (214-975)

**Dimensions inch (mm)**

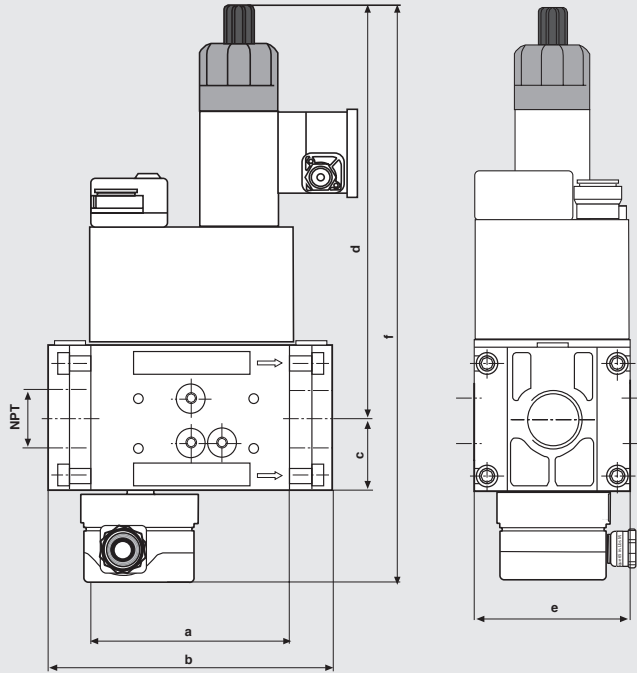

Type	Order No.	Power* [VA]	Dimensions [inch]						Weight [lbs]
			a	b	c**	d	e	f	
<b>DMV-ZRD 701/612</b>	244-730P	70	<b>3.7</b>	<b>5.6</b>	<b>1.4</b>	<b>7.5</b>	<b>2.9</b>	<b>11.5</b>	<b>6.6</b>
			93	141	35	190	73	292	3.0
<b>DMV-ZRD 702/612</b>	244-732P	120	<b>4.9</b>	<b>6.9</b>	<b>1.8</b>	<b>10.0</b>	<b>3.9</b>	<b>14.4</b>	<b>14.3</b>
			124	174	45	255	101	366	6.5
<b>DMV-ZRD 703/612</b>	244-734P	135	<b>4.9</b>	<b>7.9</b>	<b>1.8</b>	<b>11.0</b>	<b>3.9</b>	<b>15.4</b>	<b>18.0</b>
			124	201	45	280	101	391	8.2
<b>DMV-ZRDLE 701/612</b>	244-731P	70	<b>3.7</b>	<b>5.6</b>	<b>1.4</b>	<b>8.5</b>	<b>2.9</b>	<b>12.5</b>	<b>6.8</b>
			93	141	35	215	73	318	3.1
<b>DMV-ZRDLE 702/612</b>	244-733P	120	<b>4.9</b>	<b>6.9</b>	<b>1.8</b>	<b>10.6</b>	<b>3.9</b>	<b>15.0</b>	<b>14.5</b>
			124	174	45	270	101	381	6.6
<b>DMV-ZRDLE 703/612</b>	244-735P	135	<b>4.9</b>	<b>7.9</b>	<b>1.8</b>	<b>13.0</b>	<b>3.9</b>	<b>17.4</b>	<b>18.3</b>
			124	201	45	330	101	442	8.3

\* Inrush current and full load current have the same VA rating.

\*\* When using with the vent line adapter assembly, add 1.65" to dimension c. (see vent line adapter information sheet)

 **DMV-ZRD(LE) 7../612 flanges and other accessories are interchangeable**

Valve	Flange	NPT	Rp
DMV-ZR 701	<b>1/2"</b>	222-371	222-341
DMV-ZR 701	<b>3/4"</b>	222-368	222-342
DMV-ZR 701	<b>1"</b>	221-999	222-001
DMV-ZR 702 & 703	<b>1"</b>	222-369	222-343
DMV-ZR 702 & 703	<b>1 1/4"</b>	222-370	222-344
DMV-ZR 702 & 703	<b>1 1/2"</b>	222-003	221-884
DMV-ZR 702 & 703	<b>2"</b>	221-997	221-926

**DIN-Connector** 210-319  
**Visual indicator** 217-665

 **Order flanges, position indicators and gas filters separately**

**Integral Filter & Strainer**

DMV-ZR 701	230-440
DMV-ZR 702	230-441
DMV-ZR 703	230-441

**Dual Safety Shutoff Valves**  
**Two-stage operation**  
**with Proof of Closure**  
**DMV-ZRD/612,**  
**DMV-ZRDLE/612**



**Flow curve**

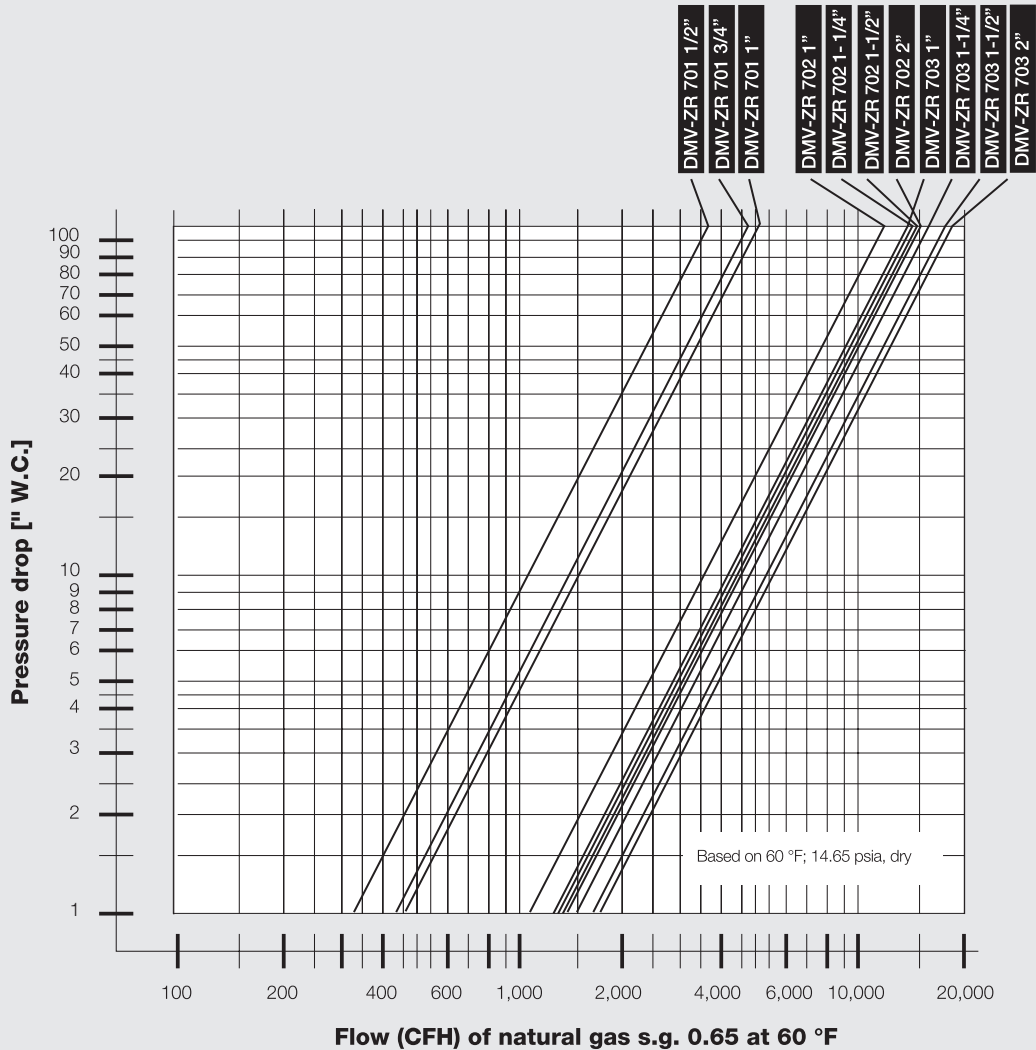

**NOTE: Size valve for at least 2 in. W.C. of pressure drop or more if the inlet pressure in the application is 1/2 in. W.C. or less. Otherwise, the difference in flow rate between stage 1 and stage 2 will be noticeable.**

We reserve the right to make any changes in the interest of technical progress.

**Karl Dungs Inc.**  
**524 Apollo Drive, Suite 10**  
**Lino Lakes, MN 55014, U.S.A.**  
**Phone 651 792-8912**  
**Fax 651 792-8919**  
**e-mail info@karldungsusa.com**

5 ... 5 Internet <http://www.dungs.com/usa/>

**Karl Dungs GmbH & Co. KG**  
**P.O. Box 12 29**  
**D-73602 Schorndorf, Germany**  
**Phone +49 (0)7181-804-0**  
**Fax +49 (0)7181-804-166**  
**e-mail info@dungs.com**  
**Internet <http://www.dungs.com>**