

Gas and air filter

GF / 3
DN 40 - DN 100
GF
DN 125 - DN 200

DUNGS®

11.03



Technical description

Filter for interior gas lines as per DIN 3386 with high dust storage capacity.

Flange connection as per DIN 2501 Part 1 to fit preweld flange as per DIN 2633 corresponding to ISO 7005-2 (PN 16).

Maximum recommended pressure difference:
10 mbar

Installation option for pressure measurement point for filter monitoring.

Application

GF/3 and GF gas and air filter to protect downstream fittings. Filter suitable for gases of families 1, 2, 3 and other neutral gaseous media.

Approvals

EC type test approval as per EC Gas Appliance Directive:

GF 4... CE-0085 AQ7127

EC type test approval as per EC Pressure Equipment Directive:

GF 4... CE0045

Approvals in other important gas consuming countries.

Specifications

Nominal flange size	DN 40 DN 50 DN 65 DN 80 DN 100 DN 125 DN 150 DN 200
Flange connection as per	DIN 2501 Part 1 to fit preweld flange as per DIN 2633 (PN 16), ISO 7005-2 (PN 16).
Max. operating pressure	4.0 bar
Pressure stage	PN 4
Max. pressure difference	≤ 10 mbar, maximum recommended pressure difference when new
Ambient temperature	-15 °C to +80 °C
Pore width of filter element	≤ 50 µm
Measuring gas connection	G1/4 as per DIN ISO 228 upstream and downstream of filter element, on left of housing
Materials	Housing aluminium cast Seals NBR Random laid nonwoven fabric PP Support frame Stainless steel
Installation position	Any, preferred position: with cap vertical

Functional description

Filter designed for installation in interior gas lines and compressed air lines to protect downstream fittings. Filter element made of random laid nonwoven polypropylene fabric and metal support frame with pore width of ≤ 50 µm.

Dust, chips and rust as well as other physical gas-accompanying materials and fouling are retained by the random laid nonwoven fabric.

If the dust storage capacity is exceeded or if there is an excessive pressure difference, the filter loses its protective function.

Installation

Refer to gas flow direction indicated by arrow on filter housing.

Provide sufficient space for changing the filter element.

If the filter cap is mounted in vertical position, it is easier to clean the filter housing.

After installation, perform leak test.

Important: Avoid direct contact between hardening masonry, concrete walls, floors and filter.

Change filter element

- At least once a year
- If pressure difference has increased by 100% compared to new filter
- When pressure difference exceeds 10 mbar

Filter monitoring

The G 1/4 screw plugs can be replaced with suitable screw connections. This permits the connection of an gas differential pressure switch to monitor pressure difference.

GF .../3 gas filter section

- 1 O ring
- 2 Cover
- 3 Housing
- 4 Filter element

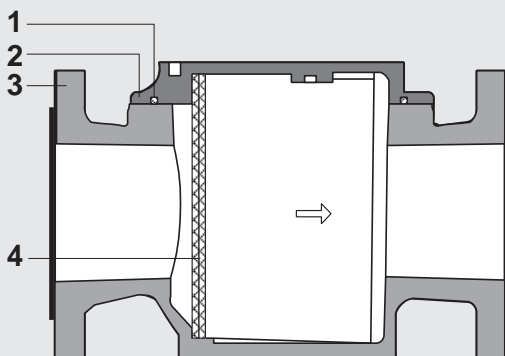

Filter monitor

- A** G1/4 screw connection
B Differential pressure switch for gas

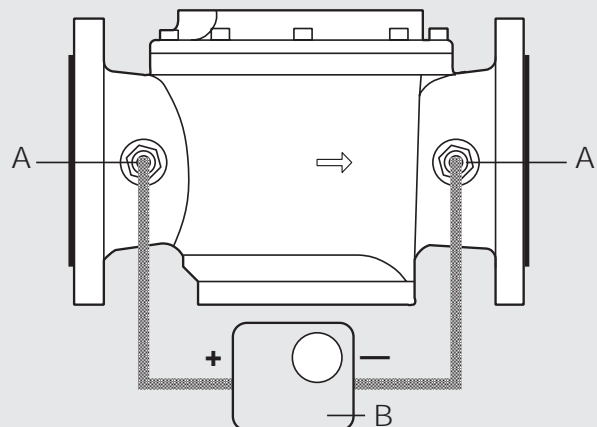

Dimensions (mm)

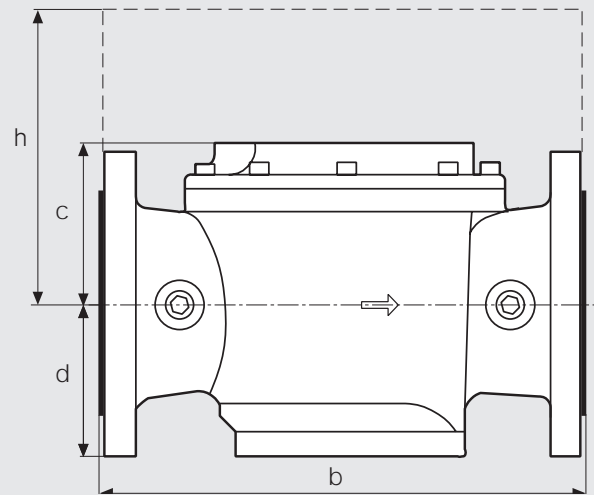
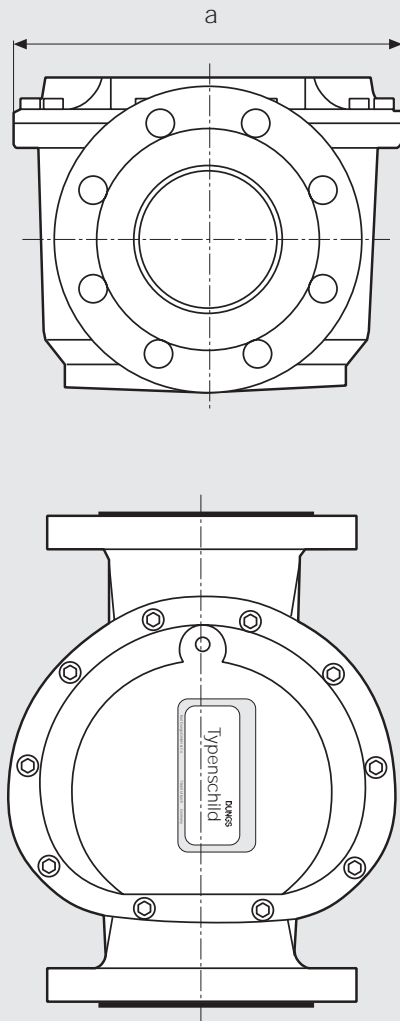

h Space requirement for changing filter element

Type	Order No.	Max. operating pressure [bar]	DN connection	Dimensions [mm]					Weight [kg]
				a	b	c	d	h	
GF 40040/3	222 637	4.0	DN 40	132	195	49	47	96	2.8
GF 40050/3	222 638	4.0	DN 50	159	211	69	50	119	3.6
GF 40065/3	222 639	4.0	DN 65	194	256	93	95	188	5.7
GF 40080/3	222 640	4.0	DN 80	234	294	105	101	206	7.9
GF 40100/3	222 641	4.0	DN 100	281	353	119	110	229	11.8
GF 40125	218 162	4.0	DN 125	281	360	182	183	365	19.5
GF 40150	218 163	4.0	DN 150	281	385	257	259	516	25.5
GF 40200	218 164	4.0	DN 200	388	455	236	239	475	40.0

Gas and air filter

GF / 3
 DN 40 - DN 100
 GF
 DN 125 - DN 200

DUNGS®

Volumetric flow/pressure drop characteristic

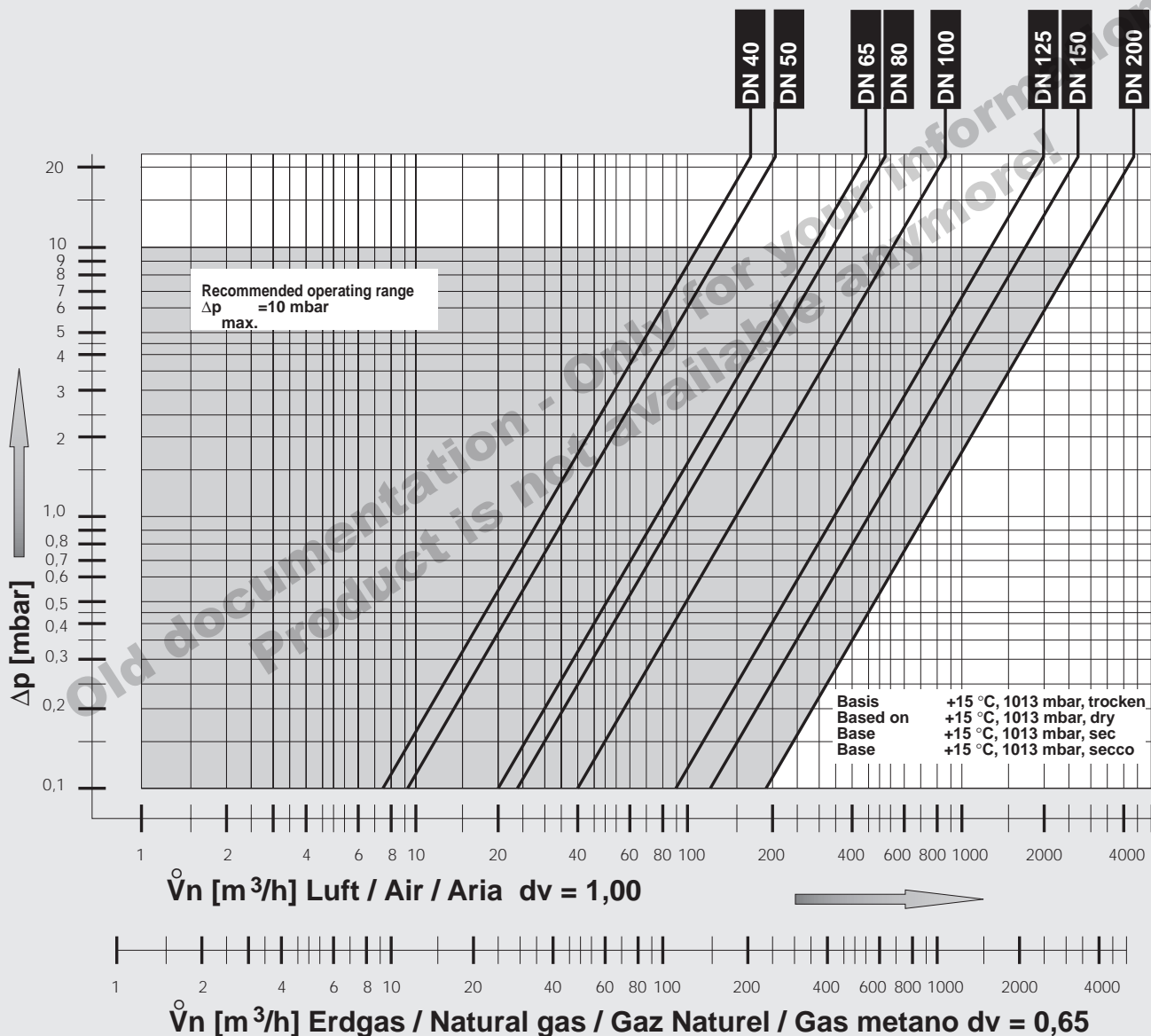

We reserve the right to make any changes in the interest of technical progress.

Head Offices and Factory
 Karl Dungs GmbH & Co. KG
 Siemensstraße 6-10
 D-73660 Urbach, Germany
 Telephone +49 (0)7181-804-0
 Telefax +49 (0)7181-804-166

Postal address
 Karl Dungs GmbH & Co. KG
 Postfach 12 29
 D-73602 Schorndorf, Germany
 e-mail info@dungs.com
 Internet www.dungs.com